

# HIGH PERFORMANCE GLOBE VALVES

## BOLTED BONNET OR PRESSURE SEAL

Our Globe Valves with fully body-guided have excellent ability to handle flow at high-pressure differentials.

To improve flow throttling, they can be equipped with special Skirt disc or Throttle disc.

Globe Valves are according to:

API-623 & API-602 Standard - for Oil & Gas  
ASME B16.34 / MSS SP-144 - for Power Generation



*All classes and sizes in  
different configurations  
and all materials*

- "T" Pattern
- "Y" Pattern
- Angle Pattern



*"T" pattern Globe  
bottom guided Standard disc*

*"Y" pattern globe  
fully body-guided skirt disc*

Skirt Disc permits high capacity at high lifts with only a moderate pressure drop.

*Comparison curves of typical Standard Disc and Skirt Disc*

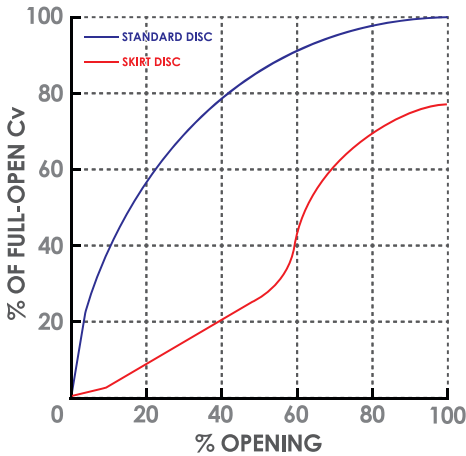

Standard Disc

The standard globe valve disc gives rapid increases in flow for low increment of lift. This is not desirable in many applications where the valve is used for controlling the flow rate.



Skirt Disc

Once the cone lifts entirely out of the seat it permits high capacity at high lifts with only a moderate pressure drop penalty.

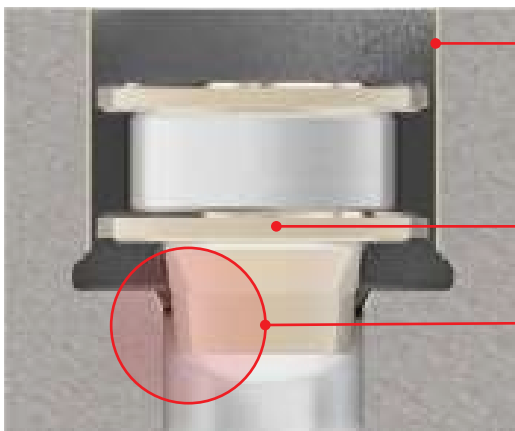

Skirt Disc & Seat

Body Guides  
(Optional hard faced)

Hard Faced  
disc guide

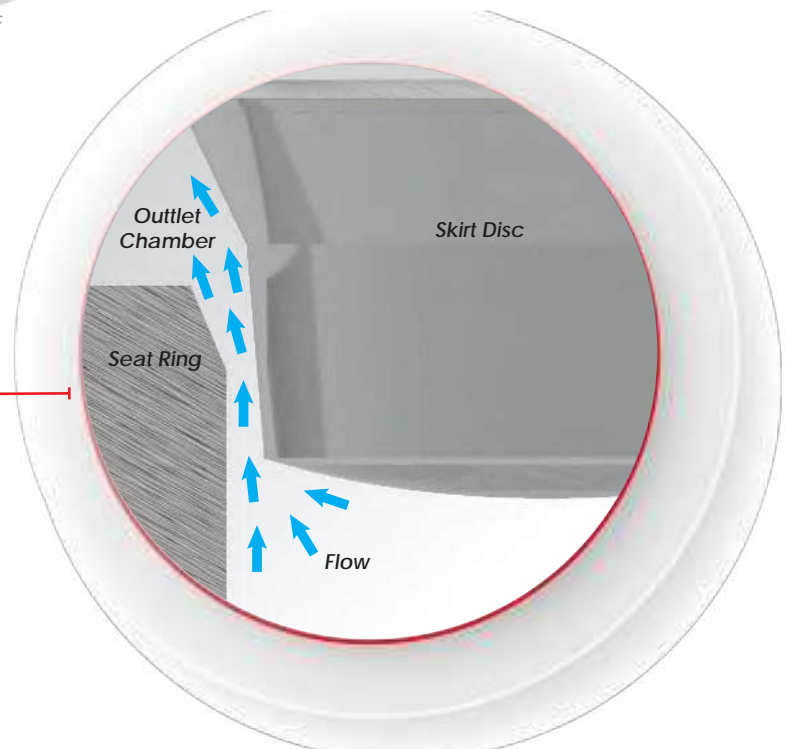

Detail of Skirt Disc & Seat

The Globe valves for high throttling applications are provided with full Stellite®\*\* hard faced surfaces on contoured Disc and Seat Ring.

*\*This material resist erosion and cavitation*

The high-pressure drop in Globe Valves require a body guided plug to resist vibrations induced by high flow velocity in the Valve Throat.

Ensures good alignment of the disc with the valve seat and eliminate all side-thrust problems.

*Fully Body-guided Design in Globe & Stop Check Valves*

Conventional body-guided designs may lead to sticking problems due to foreign material entrapment in some systems. **Xanik** offers the disc guides normally hard faced and the body is designed with internal ribs to minimize contact surfaces and to allow the foreign materials pass through the disc.



Detail Top View of Skirt Disc & Internal Ribs

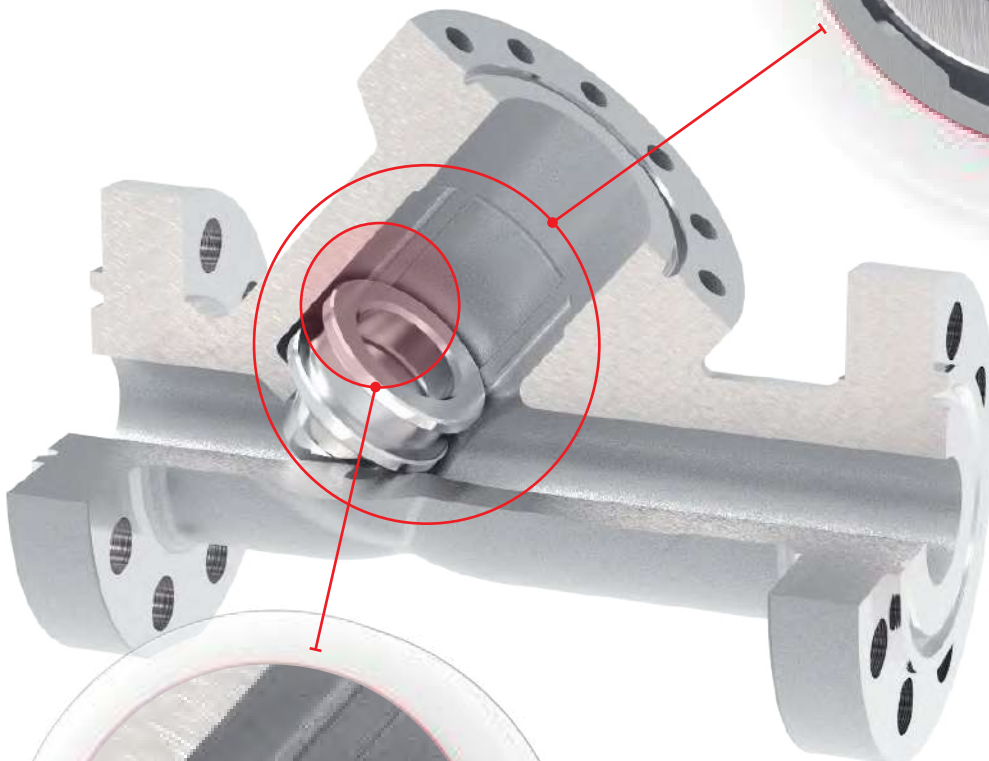

Body & Skirt Disc



Detail of Skirt Disc & Internal Ribs

The body ribs allow the flow to pass around the disc, permitting the **Xanik**® stop check or lift check valves respond rapidly to flow when it's opening.

## Non-rotating stem permits easy automatization and better performance of the packing to provide lower fugitive emissions.

### Designs Features Globe & Stop Check valves with Non-Rotating Stem

- **Impact handwheels.**

The required torques on globe and stop check valves are higher than gate valves. With impact handwheels, the torque is achieved without the need of extra rim-pull. Impact handwheels provide from 3 to 7 times the torque of the standard handwheel of the same size.

- **Stem nut** material with low friction coefficient which reduces torque, stem wear and eliminate galling

- **Stem and packing chamber** finishes to get the minimum fugitive emissions.



Detail of Disc & Seat on Angle Pattern Globe Valve

- **Preferred trims.**

Body seat ring and disc are hard-faced with Stellite® to provide a longer service life. In high throttling applications Stellite® resist more erosion and cavitation than any available trim material.

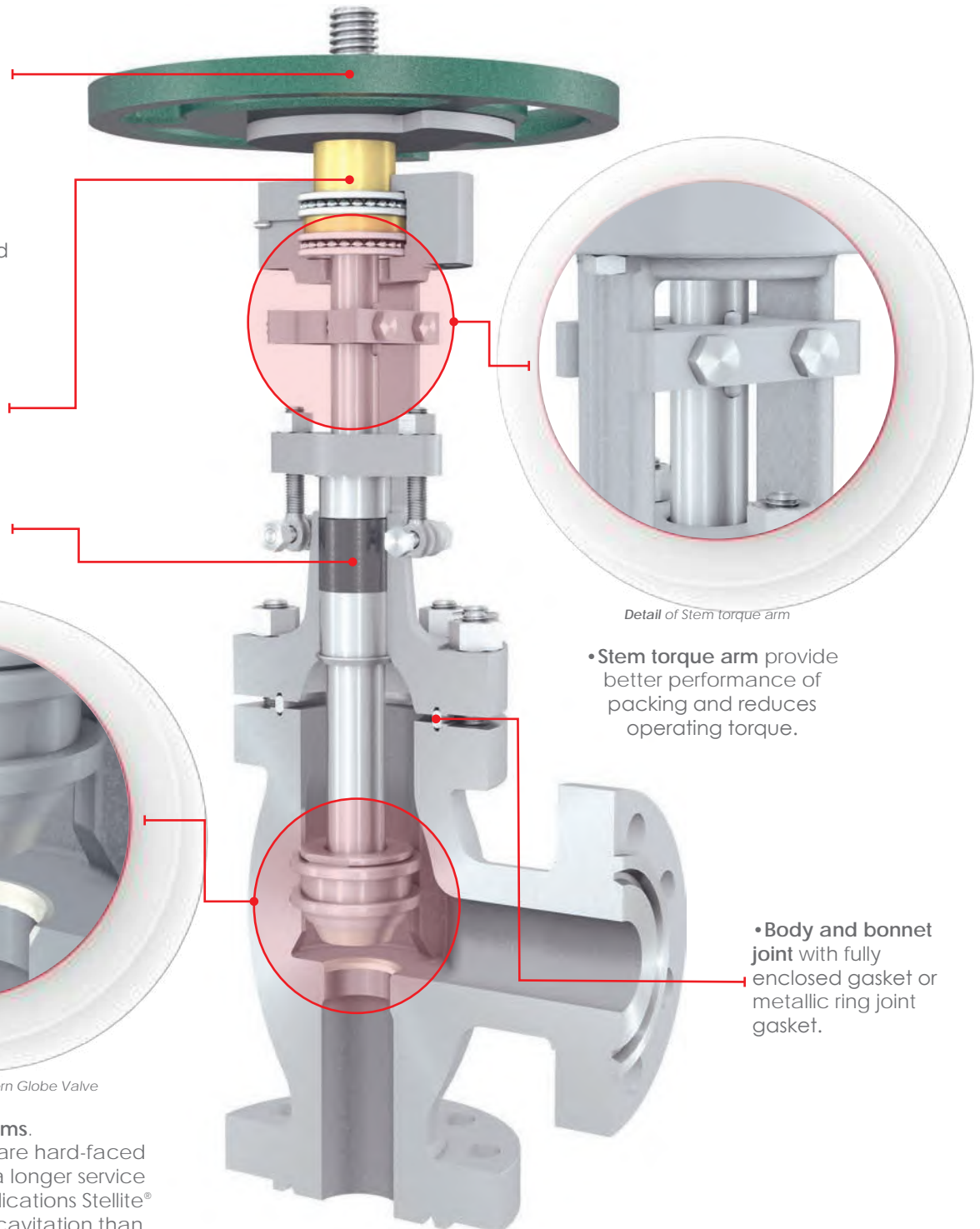

Detail of Stem torque arm

- **Stem torque arm** provide better performance of packing and reduces operating torque.

- **Body and bonnet joint** with fully enclosed gasket or metallic ring joint gasket.

Angle Pattern Globe Valve

*Designs Features Globe & Stop Check valves with Non-Rotating Stem*

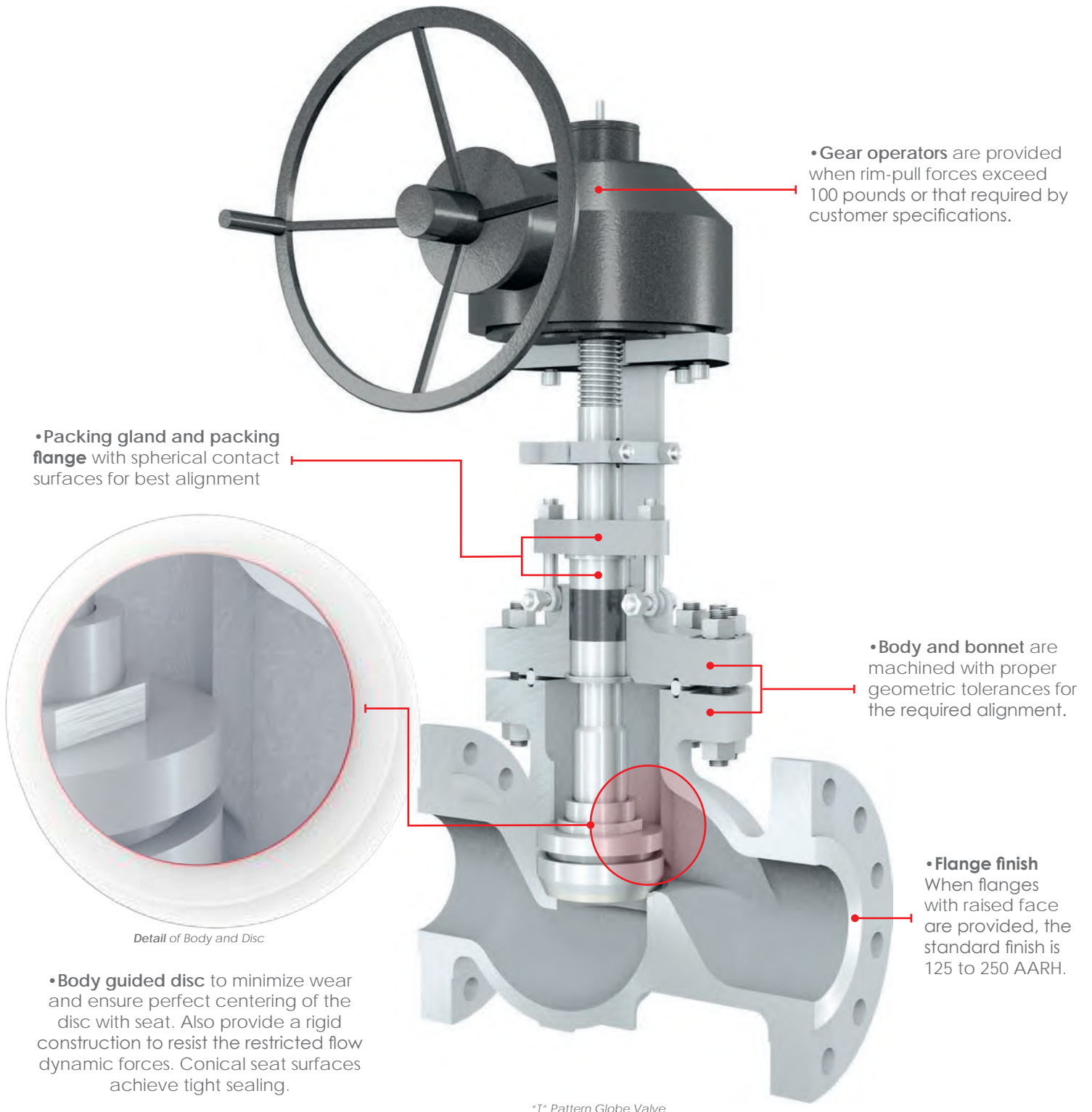

## “Y” Pattern Body to provide optimized flow passages avoiding direction changes and reducing pressure drop at full opening.

### Designs Features Globe & Stop Check valves with “Y” Pattern Body on Bolted Bonnet

When “Y” Pattern Stop Check is used the  $C_v$  at full open position is comparable to a Swing Check type valve with the capability of controlling low flow applications also.

Non-rotating stem permits easy automatization and better performance of the packing to provide lower fugitive emissions.

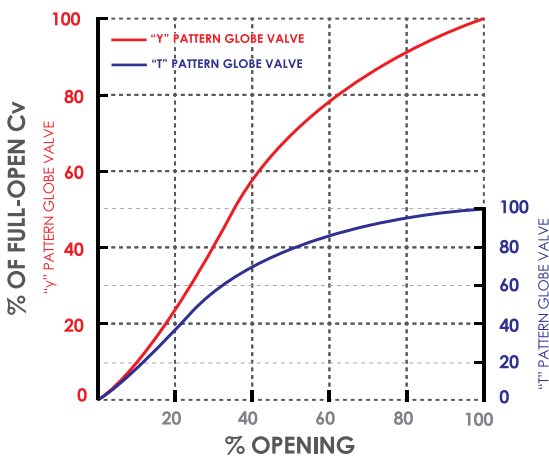

The  $C_v$  is almost the double of that for “T” pattern body.

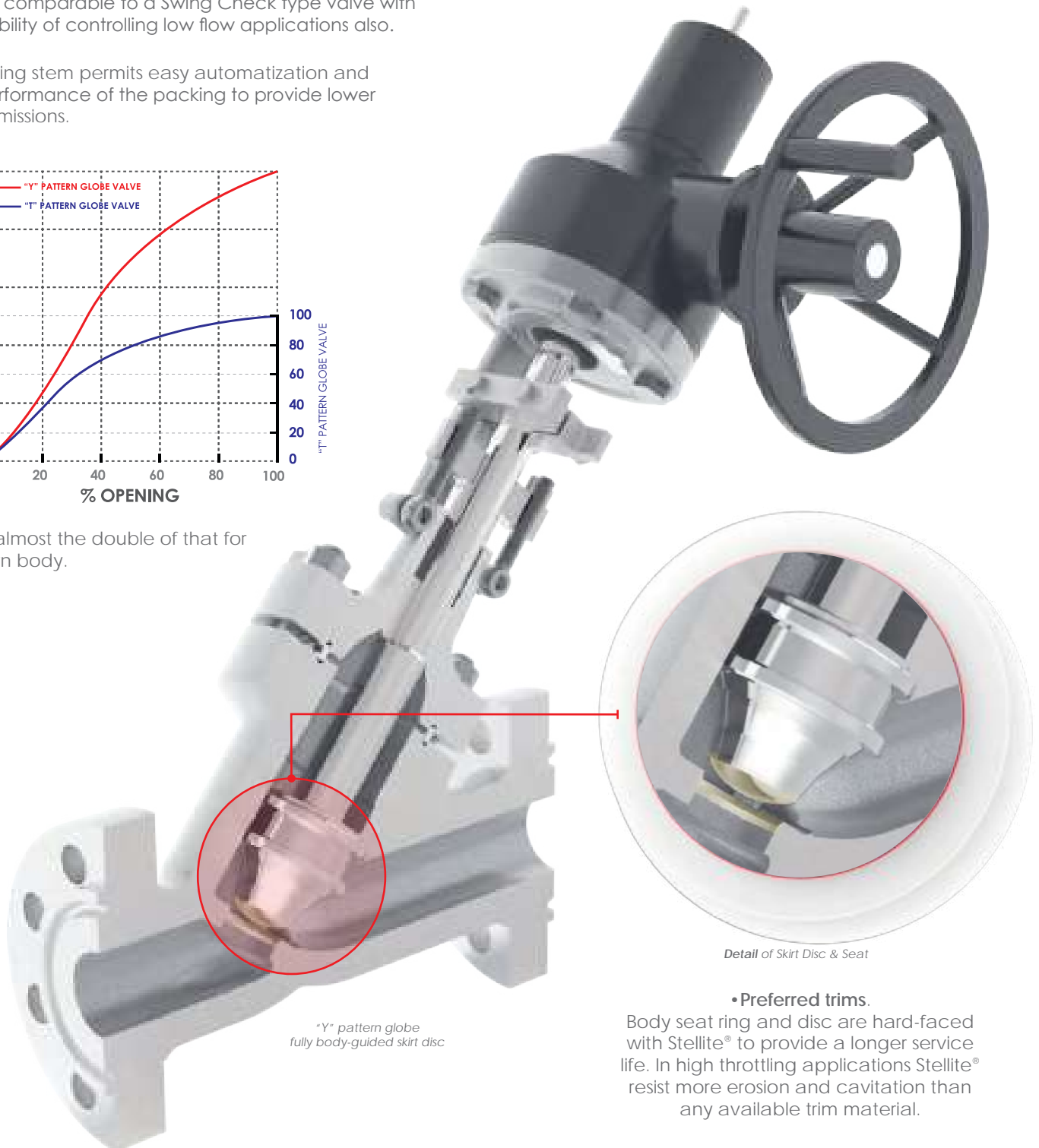

“Y” pattern globe  
fully body-guided skirt disc

Detail of Skirt Disc & Seat

• Preferred trims.

Body seat ring and disc are hard-faced with Stellite® to provide a longer service life. In high throttling applications Stellite® resist more erosion and cavitation than any available trim material.

All Globe Valves can be supplied in Pressure Seal configurations for high pressures and high-temperature applications.

*Designs Features Globe & Stop Check valves with "Y" Pattern Body on Pressure Seal Bonnet*

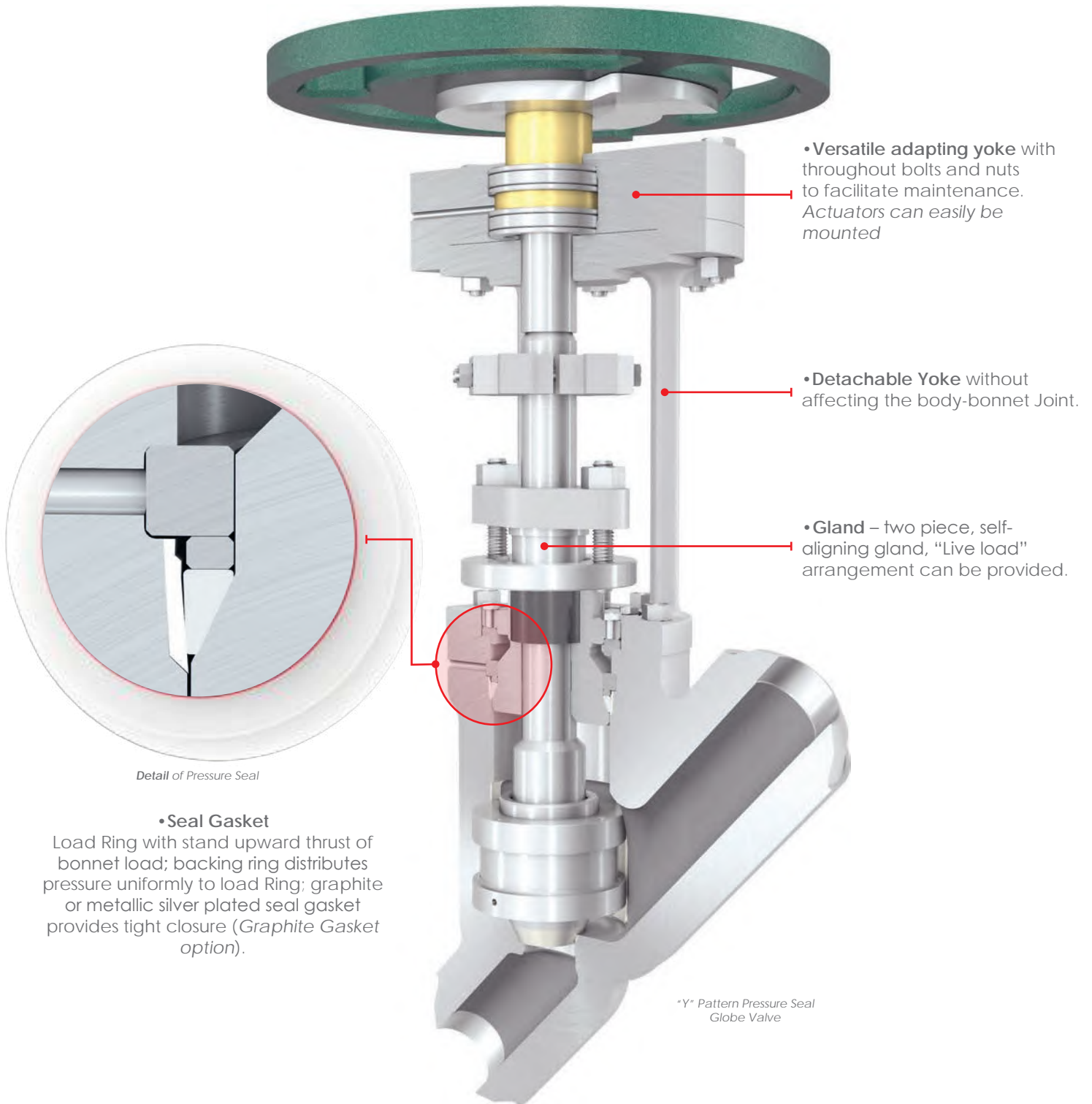

Detail of Pressure Seal



# xanik®



xanor de méxico, s.a. de c.v.

Xanik® valves are manufactured exclusively by:  
**Xanor de México, S.A. de C.V.**

Av. San Luis Tlatilco No. 24.  
Parque Industrial Naucalpan, Naucalpan.  
Edo. de México C.P. 53489, **México.**

 +52 (55) 5148 1021     [sales@xanik.com.mx](mailto:sales@xanik.com.mx)

 +52 (55) 5148 1022     [ventas@xanik.com.mx](mailto:ventas@xanik.com.mx)



Know more about our valves

