



SLADE

PATENTED SEALING PRODUCTS



PRODUCT CATALOG



FIRE SAFE



LEAK FREE



EMISSIONS SAFE



FLUSH FREE



TABLE OF CONTENTS

- I. LETTERS FROM THE COMPANY
- II. SLADE 3300 SERIES PACKING
- III. SLADE WIRE RE-INFORCED GRAPHITE PACKING
- IV. INDUSTRIES SERVICED
 - PAPER MILL
 - POWER PLANT
 - REFINERY
 - MARINE
- V. PRODUCTS
 - ASPHALT PUMP PACKING
 - SOOT BLOWERS
 - W2S LANTERN RINGS/SPACER BUSHING
 - DSS/EFOIL RINGS
 - PCK (COMPRESSION TOOL)
 - PYRO-TEX JOINT SEALANT
 - PYRO-TEX SHEET GASKET
- VI. CERTIFICATIONS
- VII. CASE HISTORIES
- VIII. DATASHEETS



Manufacturer of Carbon Fiber Reinforced Graphite Foil

SEALING TECHNOLOGISTS TO THE CHEMICAL PROCESSING INDUSTRIES

181 Crawford Rd.
Statesville, NC 28625 USA
www.slade-inc.com

Office: (704) 873-1366
Fax: (704) 873-1399

Slade 3300i Low Emissions Valve Packing Tested and Passed API 622, 2nd Edition

Slade is a forerunner in fluid sealing technology, providing the industry with patented expanded graphite packing, field tested and proven for many years. Due to ever increasing regulations to fugitive emissions throughout the world, a recognized standard has been set for the entire packing industry.

API 622 2nd Edition Testing at a Glance

Emissions – Five day test consisting of 150 ambient cycles, 150 thermal cycles (500°F) per day, total of 1500 cycles at 600psig. Methane used as the test gas.

Corrosion - 35 day test, packing samples soaked in de-mineralized water for 24 hours, installed in a compression fixture under 4350 psi, water temperature 300°F, ±30°F, water pressure maintained at 650psig. Report on degree of stem pitting.

Materials – Sample weights compared prior to test and after 300°F, 500°F, 1,000°F. Record of density. Testing for total lubricant and TFE content.

Slade 3300i Performance

Slade 3300i has been tested to the API 622 standard by Yarmouth Research and Technology, with an average leakage of 10ppm and a **final reading after 1500 cycles, of only 4ppm**. For the corrosion portion of the test, **Slade 3300i showed 0% stem pitting or corrosion**.

Slade 3300i Low Emissions Valve Packing provides a high temperature, **fire safe, sealing solution** needed to **reduce VOC emissions** without causing damage to the valve stem or body.

Slade 3300i is constructed of Slade patented carbon reinforced expanded graphite yarns. Providing a truly unique valve packing that is manufactured in the USA.

Our Commitment to Progress

Slade 3300i was developed and tested through our in-house testing facility. Our research continues to improve the sealing products that today's ever changing world demands. It is our goal to always provide the quality, and customer care that Slade customers have come to appreciate.

For further information on Slade 3300i or any other Slade products, please feel free to contact us:

Phone: 704-873-1366

Email: sales@slade-inc.com

Website: www.slade-inc.com

181 Crawford Road
Statesville, North Carolina USA 28625
www.slade-inc.com

Office: (704) 873-1366
Fax: (704) 873-1399
E-mail: sales@slade-inc.com

SLADE 3300 Controls Fugitive Emissions

SLADE, Inc. (U.S. manufacturer) is the designer and manufacturer of Emissions Control Valve Packing, utilizing Slade's own patented braiding yarns. Slade Foil 3300 is well known for its ability to achieve *better than* the EPA 1997 Standard of **100 ppm** in VOC Emissions, and will supply you with independent reports from leading Refineries / Chemical Plants testifying to such (ask for "The Cambridge Report" and the "Corpus Report").

We are very proud of the fact that we are approved by major companies for VOC controls. As an example, here is a partial list:

- (1) **Exxon Specification:** Effective April 1, 2003, Exxon approval "AML Part II, Section 10.1 and Section 10.3." Products approved: "Slade 3300G and 3300W, manufactured in Mooresville, NC." AML issued by Ray Bojarczuk – EMRE AREO.
- (2) **Shell Global Specification:** Shell SPE 85/200 "Guidance for Packing Braids and Styles;" Product Group Code: **85AA.AD**; Type: **3G**; MESC Range: **85.15**; (Also known as "SPE 85/200, Group 3G") (issued 2/22/01).
- (3) **Chevron Specification:** "M-501, Appendix II, paragraph 4.3", issued 3/94." Which reads: "Slade 3300G Braided Graphite end rings (2) and 3 or 4 *identical* braided graphite center rings, quantity depends upon depth of packing chamber – all cut to fit. Compression: 25%." (Italics ours).
- (4) **DuPont Specification:** DuPont Packing Code: **SU1C-R39, Table #1**. Code R39 calls for "Ultra low emission graphite based braided packing," Revised March 1996.
- (5) **Petroleum Environmental Research Forum (PERF):** In June of 1996, **Exxon USA** tested Slade 3300 to "**PERF**" specifications. The methodology of this test is the installation of 5 rings of "spooled" packing (cut, NOT die-formed) into a gate valve, cycling the valve 1,100 cycles, with 5 thermal cycles (to 600 F) and obtaining fugitive emissions reading, using EPA Method 21. It compares spooled packing emissions to die-formed rings of Grafoil, Slade passed with flying colors, with an ending reading of only "**15 PPM**," whereas die-formed Grafoil had a final reading of 473 PPM.

Slade 3300 is certified "**API 589**" and "**API 607**" (w/Exxon sanctions)" Fire Safe. Slade Foil 3300 achieves this emission control "off *the spool*." In other words, **die-forming is not required**. In addition, **no special end rings** are required, 3300 is used throughout the packing stack. For containment of Fugitive Emissions, **specify Slade 3300**.

181 Crawford Road
Statesville, North Carolina USA 28625
www.slade-inc.com

Office: (704) 873-1366
Fax: (704) 873-1399
sales@slade-inc.com

To: All Slade Agents

From: Bob Crosier

“We have the same as Slade 3300G”

Situation: After you prove Slade’s effectiveness, the competitor tells your customer “that we have a product as good as Slade.”

Prepare your customer for these claims, and suggest that he get his answers in writing.

1. How long have you been making this product? Slade began in 1989, when did you begin?
2. Am I going to be a guinea pig on this? Do you have the same field tests, case histories, and experience that Slade does?
3. Why haven’t you told me about your product before?
4. If it is an equivalent to Slade’s, what documentation do you have?
5. May I have copies of the test results performed by independent laboratories?
6. Is it exactly the same? If it is, do you have a licensing agreement under Slade’s patent to make it?
7. Are you saying that it is exactly the same or that “in your opinion” it is just as good as Slade’s? What do you base your opinion on? Does it include long-term field tests, laboratory tests, etc?
8. Does it pass the API Fire Tests with the 95% margin that Slade’s does? Who performed these tests?
9. Is it “Fire Safe” according to industrial definition of that term, or is it in your opinion fire safe?
10. Has Exxon performed emission tests at their laboratory in Florham Park, New Jersey? Did yours perform 76% better than the die-formed flexible graphite foil set used as a benchmark at Exxon?
11. If yours performs as well as Slade, why did you wait until I heard about this technology from Slade? Why haven’t you told me about it before? Is there a reason why you have kept this a secret from me?
12. Does your company make its own braiding yarns like Slade does or does it come from a third party? What is your source?
13. Do you have exactly the same ratio of carbon fiber to graphite that Slade’s does? Is that important?
14. Will you give me a lifetime valve warranty equal to Slade’s?
15. Will your company provide the answers to these questions in writing?
16. Does your run without flush water?
17. Can yours run virtually without leakage?

SEALING TECHNOLOGISTS TO THE CHEMICAL PROCESSING INDUSTRY

181 Crawford Road
Statesville, North Carolina USA 28625
www.slade-inc.com

Office: (704) 873-1366
Fax: (704) 873-1399
sales@slade-inc.com

For Immediate Release: March 20, 2000

To: The Valve Industry

Re: New Slade **Enviro-Foil Spacer Bushings™**

SLADE Fluid Sealing is pleased to announce the release of its new **Enviro-Foil Spacer Bushings**. Slade has developed a technology for making extremely dense, braided composite (graphite and 316 SS) bushings that install exactly like die-formed rings of braided packing. These bushings replace fragile machined split-carbon bushings.

According to EPRI (Electric Producer Research Institute), more than 5 sealing rings have a negative effect on valve sealing capability. Currently the practice is to machine carbon bushings to act as spacers.

Common Complaints of Machined Split-Carbon Bushings:

- ❖ Long lead times
- ❖ Fragile carbon often cracks or chips during installation
- ❖ Bushings are often too long to fit the clearances between the valve body and the stuffing box cavity
- ❖ The bushings are covered with carbon dust
- ❖ Stuffing box depth is unknown, making it impossible to order correct carbon bushing lengths
- ❖ High costs

SOLUTION: Slade's patented technology permits the braiding and die-forming of the unique "Enviro-Foil Spacer Bushings". The product is made from strands of 316 Stainless Steel foil encapsulated in graphite foil, which are braided exactly like packings. The braided composite is cut to size and die-formed enormous hydraulic force, producing a ring of extreme density. The rings are substantially larger on the ID than the stem diameter to prevent frictional interference with operation of the valve stem.

Benefits of Slade Enviro-Foil Spacer Bushings:

- ❖ Easy to install, one-piece construction (no split-halves to match up)*
- ❖ No machining required
- ❖ Critical stuffing-box *depth* dimensions not required, add as many rings as necessary
- ❖ Lower Costs
- ❖ Improves seal ability of most valve packings (lower fugitive emissions)
- ❖ Tough composite construction, will not fracture or crack
- ❖ Inventories reduce to ID/OD dimensions only, depth is not longer a factor

*The ring has one joint, which is separated and formed into an "S" shape to facilitate installation without kinking the ring.

Want to see a sample? Fax a request to us at (704)873-1399 or request one from sales@slade-inc.com
Ask for:

Enviro-Foil Spacer Bushings

Member FSA: Fluid Sealing Association

Slade 3300™

the “Mechanical Seal on a Spool”™



Made in USA

Patented Technology

**Eliminate
Seal Water,
Stop Most
Leakage.**

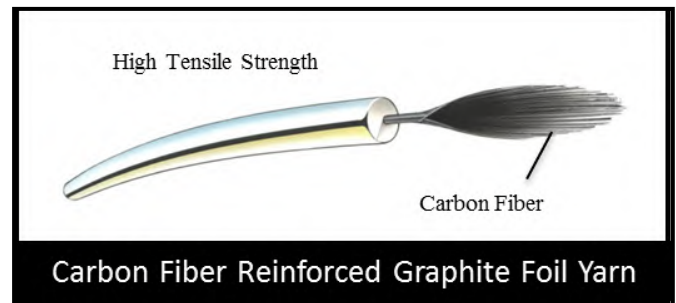

**An annual savings of \$13,140
per rotating shaft***

**Assumes 5 gallons per minute of water at \$.005 cost per gallon*

*Pulp and Paper Mills, Nuclear, Fossil and Hydroelectric Power Plants,
Waste Water Treatment Plants*

- **Reduces amperage**
- **4800fpm (1400m/min)**
- **Seals abrasive slurries**
- **Water savings (per shaft): 2.6 million gallons per year (@5gpm)**

SLADE

Slade Inc. · 181 Crawford Rd · Statesville, NC 28625 · USA

Website: www.slade-inc.com · Email: sales@slade-inc.com

Tel: 704-873-1366 · Fax: 704-873-1399

Distributed By:



VOC Emission Valve Packing

96% of valves packed with Slade have ZERO emissions

• Slade manufactures its own patented graphite foil yarns to achieve these standards.

• Outstanding performance under API 589 and 607 Fire Test specifications (API Testing performed by Southwest Research Institute).

• Two independent tests (PERF standards) by Major Oil Company show emission control 3.9 and 6.4 times better than (1/5 stack) die formed rings of flexible graphite foil.

• Slade graphite foil die-formed rings are TA Luft Certified to VDI Guidelines 2440 for temperatures above 480 °F/250 °C

Fugitive Emission Control

3300C – Slade's Cost Effective Pump & Valve Packing

Reinforcement: Each individual strand of graphite foil is reinforced with high strength structural carbon fiber and no other reinforcements
Temp: -400°F/-240°C to 1800°F/1000°C
Pressures: Valves to 4500 psi / 310 bar (for high pressures, consult factory)
pH range: 0-14, except in strong oxidizers
3300W: Inconel® wire reinforced for higher pressures: 5,000 psi / 345 bar
3300GLC: Low chloride, high purity version for nuclear plants

3300G – Slade's best All Purpose Pump & Valve Packing

Reinforcement: Corners and each individual strand of graphite foil are reinforced with high strength structural carbon fiber, no other reinforcements
Temp: -400°F/-240°C to 1800°F/1000°C
Pressures: 5,000 psi / 345 bar without end rings (compress 30%)
Pumps: Flush-free in many applications to +4800 fpm (1,400 m/min)
pH range: 0-14, except in strong oxidizers
Application: Chemicals, steam, hydrocarbons, etc.
3300GLC: Low chloride version for nuclear power plants

3300K – Slade's Best Triplex, Reciprocating Pump Packing

Reinforcement: Same as 3300C except Kevlar fiber corners
Temp: Maximum temperature 500°F/260°C
Application: Reciprocating/plunger, wastewater, steam and ammonia pumps, oil well sucker rods, etc.
Pressures: 5,000 psi / 345 bar
pH range: 2 - 12

3300CJ – Slade's Cost Effective Pump & Valve Packing

Description: Carbon fiber jacketed 3300C
Pressures: Valves to 5,000 psi / 345 bar; 1200°F / 650°C
Application: Used as an anti-extrusion end ring
pH range: 0 - 14, except in strong oxidizers

3300CJK – Slade's Cost Effective Pump & Valve Packing

Description: 3300CJ with Kevlar corners, used as an anti-extrusion ring (for large throat clearances) and to protect against particulate contamination. Usually only one ring is installed (first ring in) at the bottom of the stuffing box.
Temp: 500°F / 260°C
pH range: 2 - 12



181 Crawford Rd. Statesville, NC 28625

Website: www.slade-inc.com

Email: sales@slade-inc.com

Phone: 704-873-1366

Fax: 704-873-1399

FIRE SAFE



EMISSION SAFE



SLADE

PATENTED SEALING TECHNOLOGY



- Low Emission
- Fire Safe
- API 622 Certified

Inconel® wire knitted
over Slade's patented
graphite yarns



SPECIFICATIONS

Temperature	1200°F / 650°C Steam 1800°F / 1000°C Inert Environment 1800°F / 1000°C Working Temp
Pressure	6000psi / 414 bar
pH	0-14 (except in strong oxidizers)

Slade 3300i style packing combines the strength of Inconel® wire, which prevents extrusion of graphite, with the resilient lubricating properties of Slade's patented, API 589 and API 607 certified fire-safe packing.

This provides you the superior performance that you expect from a low emission valve stem packing.

STYLE 3300i

THE NEXT GENERATION IN VALVE STEM PACKING

Slade Inc.

181 Crawford Rd • Statesville, NC • 28625 • USA

704-873-1366 Phone / 704-873-1399 Fax

WWW.SLADE-INC.COM



3300i

Low Emissions Valve Packing

Slade 3300i Low Emissions Valve Packing is specifically designed to meet the strictest criteria in valve emissions required within today's industry. Slade 3300i has been API 622 (2nd edition) tested and qualified with an average leakage of 10ppm, completing the 1500 mechanical cycles and 5 thermal cycles with a leakage of only 4ppm. See what makes Slade different from all of the others!

Inconel® 600

Slade utilizes Inconel® 600 as a knitted jacket around our patented expanded graphite, carbon reinforced yarns. Slade's unique design allows the Inconel® to become an internal skeleton providing strength and stability without damaging equipment.

Inconel® can be clearly seen knitted around each individual Slade yarn



After packing is braided and calendared to size, Inconel® knit becomes less visible as the graphite is pushed out through the Inconel®



Once die formed, the Inconel® knit is no longer easily visible due to the carbon fiber strands pushing out the graphite up and over the Inconel®



High Tensile Strength Core

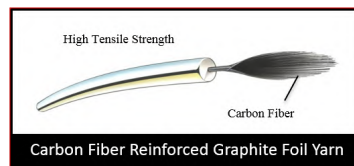

Slade's unique patented yarns include a continuous carbon core within the center that allows the structure to hold up under high temperatures, pressures and chemicals. The carbon core provides resilience for thermal cycling.

Prevents Corrosion

Slade 3300i Low Emissions Valve Packing has proven to be non-corrosive. After the 35 day corrosion test (part of the API 622—2nd edition test), there was no corrosion present. You can trust Slade with your valves, and avoid costly stem pitting by switching to Slade today!



SLADE 3300W

FIRE SAFE & EMISSION SAFE VALVE SEALING.



EMISSIONS BELOW 100ppm. API 589 & API 607 COMPLIANCE.
MEETS VOC & VHAP EMISSION CONTROL STANDARDS FOR
CHEMICAL & PETROLEUM PROCESSING INDUSTRIES.

SLADE 3300W

SLADE'S VERY BEST EMISSION CONTROL PACKING.

Typically seals VOCs to below 100 ppm.

Application Data:

Pressure: Up to 5000psi/345 bar

Temperatures: -328°F/200°C up to 1800°F/1000°C

Corrosion Resistant: For high temperature exposure and better performance in oxidizers than other graphite foils.

pH Range: 1-14 (except strong oxidizers)

Lubricity: Self lubricating, coats stem surface

Lubricants Required: No added lubrication recommended, lubricants tend to carbonize and form hard abrasive particles.

Compression: For best performance compress 3300W to its maximum density

Equipment Recommendations:

Valves and Actuators (for Rotary and Reciprocating Applications, use Slade 3300G)

Braid: Diagonal • Interlock braid

SLADE Patented Yarn

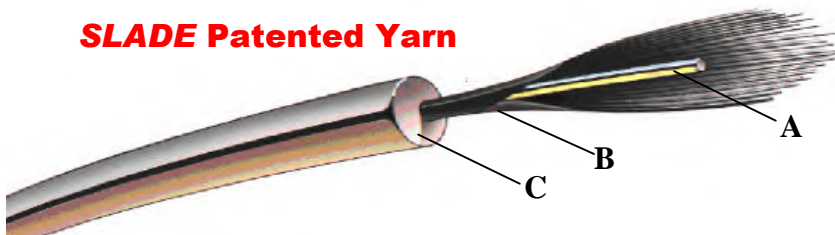

- A** 0.005" diameter Inconel® wire core, tensile strength: 100,000 psi
- B** Carbon fiber shroud of 2,800 filaments encapsulate wire core, tensile strength: 600,000 psi
- C** 0.020" thick graphite foil jacket

Corrosion Inhibitors: Specific Corrosion inhibitors may be added upon request.

Summary Remarks:

- Thermally conductive
- Non-scoring
- Resists heat
- Inert to most chemicals, acids and caustics
- Self-lubricating
- Non-hardening
- Dimensionally stable at elevated temps.
- Highest compression strength
- Highest tensile strength

Nuclear Applications: High-Purity—May be certified to meet the most stringent chemical contaminant requirements.

SLADE INC

181 Crawford Road
Statesville, North Carolina, 28625 USA
(704) 873-1366 Office
(704) 873-1399 Fax

Web Page: <http://www.slade-inc.com>

Email: sales@slade-inc.com



SLADE

ONE SOLUTION TO ALL YOUR SEALING NEEDS

PAPER MILL PACKING



- STOCK PUMPS
- DEWATERED STOCK PUMPS
- WHITE WATER
- LIQOUR PUMPS

- SHOWER PUMPS
- FIRE PUMPS
- SLUDGE PUMPS
- BOILER FEEDS

- SOLID RECOVERY PUMPS
- VACUUM PUMPS
- MIXERS
- STOCK CHEST AGITATORS



EQUIPMENT LONGEVITY

- Prevents leakage to wash-out bearings or damage to motor.
- Prevents leakage that wears sleeves.
- Protects sleeves by coating them with graphite.

WHAT MAKES SLADE DIFFERENT?

Slade manufactures all of its own patented graphite yarns right here in the USA. The advantage is that each individual strand has its own unique core made of high tensile carbon fiber (for sealing rings) or stainless steel (for anti-extrusion or bushing rings).



No special end-rings required, carbon reinforcement keeps packing from extruding.

No Lubricants! Graphite coats stem for low coefficient of friction



Distributed By:

Slade INC

181 Crawford Rd

Statesville, NC 28625

704-873-1366 / FAX: 704-873-1399



Slade Packing can be used for both Pumps and Valves which reduces your INVENTORY costs. With SLADE there is no hassle of going through catalogs to find your perfect packing

SLADE



POWER PLANT PACKING

EXCELLENT FOR ALL POWER PLANT APPLICATIONS



There's no Substitute for Experience

FOR STEAM, NUCLEAR , AND HYRDO-ELECTRIC PLANTS

PUMP APPLICATIONS

- Boiler Feed Water
- Condensate Pumps
- River Water Intake
- Vacuum Pumps
- Fly-Ash Pumps
- Auxiliary Feed-Water
- Boiler Recirculation
- Service Water Pumps
- Heater Drain Pumps
- Clinker Grinders
- Lime Slurry Pumps



SERVICE LIMITS

- Temp: 1,800 °F / 1,000 °C
- Chemical: 1-14 pH
- Pressure: Up to 5,000 PSI/345 Bar
(higher pressures use Enviro-Foil ™ Bushings as end rings)

SLADE'S DSS SEALING SYSTEM

REPLACES EXPENSIVE MECHANICAL SEALS AT 25% OF THE COST. **SPLIT TO INTSTALL WITHOUT DISMANTLING THE PUMP.**

For best leak-free, flush free service, use the DSS sealing system.

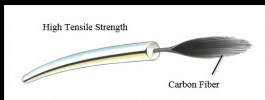
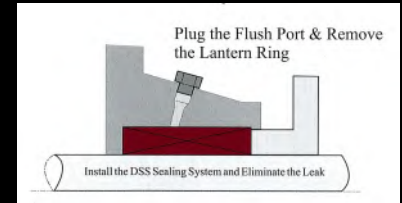

Carbon Fiber Reinforced Graphite Foil Yarn

THE SLADE PATENTED GRAPHITE YARN

More than 15 years Slade has and continues to manufacture all of its own patented graphite yarns here in the USA. The advantage is that each individual strand has it's own unique core made of high tensile carbon fiber. The yarns are protected by US & EU patents. They were developed to conduct heat like a steel alloy to transfer the heat away from the shaft.

When you compress by 25% (the denser the better), you have die-formed it into the stuffing box. This forms a "heat sink" in the stuffing box. So you don't need flush-water to cool the shaft sleeve, in most applications. In addition, SLADE reduces the number of oxidation sites in the packing yarns, so you can use 3300G in more .

DISTRIBUTED BY:

SLADE INC
 181 Crawford Rd.
 Statesville, NC 28625
 704-873-1366 Phone/ 704-873-1366 Fax





REFINERY Packing & Gasket

Valves

- Control Valves
- Block Valves

Pumps

- Reciprocating
- Rotating

End Connections

- Man and Hand Hole Gaskets
- Heat Exchangers
- Pipe Flanges
- Manifolds

Applications

- Emission Safe
- Fire Safe
- Flue Gas
- Caustics
- Hydrocarbons
- River Water
- Cooling Tower
- High Pressure
- High Temperature



One Solution for ALL Your Sealing Needs

Pyro-Tex Sheet Gasket

- Strength of stainless steel, seal-ability of graphite
- Able to handle temperatures up to 1400°F (760°)
- Able to handle pressures up to 4500 PSI (310BAR)
- Woven design produces a 'metallic leaf-spring effect'
- Flexible enough to be rolled up and shipped in tubes.
- Can be cut by hand with a pair of office shears

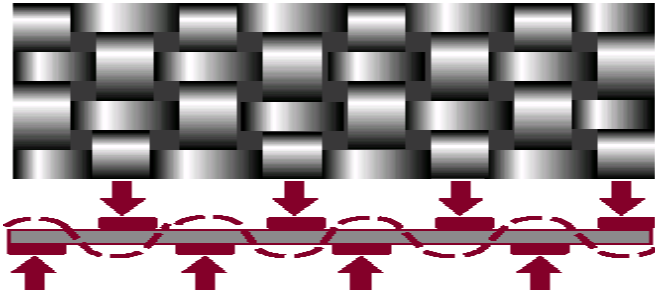

Slade starts with patented yarns reinforced with flattened strips of stainless steel, and totally encapsulated in flexible graphite. Woven into sheets 80"(2mtr) x 80"(2mtr) x 3/32"(2.3mm) and longer lengths.

Pyro-Tex Joint Sealant

Self Forming Gasket on a Spool

HP (high-pressure): made from the same patented stainless-steel foil yarns as our sheet.

Repairs leaking Heat Exchangers without having to remove the tube bundle or machining the flange faces.

Available on 50' (15mtr) spools in either:



Semi-Round

or



Rectangular



Easily installed by overlapping 45 degree angled cut ends just as you would packing rings.

SLADE, INC

181 Crawford Road
Statesville, NC 28625

Website: www.slade-inc.com

Email: sales@slade-inc.com

Phone: 704-873-1366

Fax: 704-873-1399

Distributed By:

Valves

- Lifetime Replacement Warranty on Valves
- API Fire Tested 607 and 589 at 1800°F (1000°C)
- Approved for sealing VOC by Exxon, Shell, Chevron, Dupont, Eastman Chemical & other companies
- No special end-rings required. Carbon-corners on each ring of 3300G provide excellent Anti-Extrusion and Wiper Action. good to 5000 PSI (345 BAR)
- 3300G coats stem forming composite microfinish, resulting in low coefficient of friction.
- 30% compression of spooled 3300G "die-forms into the stuffing box" eliminating the need for die-formed rings
- Reduces inventory and cost:
 - a. By eliminating die-formed rings for each valve
 - b. By having a few standard sizes for all valves
 - c. Same packing for both pumps and valves
 - d. If a leak develops, just add a ring
- Extremely high operating temperatures (typically: 1,800°F/1000°C).
- "Live-loading" not required. No weight loss at temperatures up to 1200°F (650°C)
- Highly polished surfaces are not required (finishes between 8 to 32 RMS are fine)
- Handles media within 0-14 pH (except strong oxidizers)
- No lubricants, grease or impregnates that can be squeezed, washed or cooked out
- No wire reinforcement that could damage stem

Pumps

Advantages of Slade 3300

- One packing for pumps and valves
- Works well on smoothly or worn sleeves
- Difficult to over tighten
- Virtually no leakage in most applications
- No flush water required in most applications
- Reduced amperage typical 10% to 15%
- Outlast typical packing 6 to 1
- Virtually no shaft wear

Applications

- Reciprocating pumps
- Cooling tower pumps
- Vacuum pumps
- River Water pumps
- Fire pumps
- Auxiliary pumps
- You name it pumps

Service Limits

- Temp: -400°F(-240°C) to 1,800°F(1000°C)
- Pressures: 5,000 psi (345 bar)
- Speed: 4800 fpm (1464 meters per minute)
- pH range: 0-14, except in strong oxidizers



MARINE SHAFT PACKING



- ◆ Temp Limit: 1800F/1000C
- ◆ Pressure Limit: 1000psi/70bar
- ◆ Chemical Resistance: (except in strong oxidizers): 0-14ph

“The Mechanical Seal on A Spool”

Patented Technology Revolutionizes Stern Tube Sealing

- ◆ No Cooling Water Required
- ◆ Eliminates Bilge Water
- ◆ Provides Bearing Support
- ◆ Reduces Shaft Vibration
- ◆ Self-Lubricating
- ◆ No Electrolytic Corrosion

TRY SLADE TODAY !

SEE WHY OUR CUSTOMERS WILL NEVER GO BACK TO
CONVENTIONAL PACKING AGAIN!



“Slade 3300G Packing has replaced all packing in all of our fleet vessels. The Tubes are now leak free and use a spacer bushing to even further reduce amount of packing required”

“Our Engineers and I think there are not enough words to express our compliments for the Slade Packing.” Tugboat, Work-boat, Ferry-boat, and Pleasure boat operators are saying the same thing.

Slade Works Great for Bilge Pumps, Saltwater Wash-down Pumps, Air Compressors, Steam Valves , Rudder Fins, Stern Tubes and more...

SLADE

Manufactured with a Patented Yarn that is like no other!

Distributed By:

Email: Sales@slade-inc.com
Telephone: 704-873-1366 Fax: 704-873-1399
181 Crawford Rd · Statesville, NC USA · 28625



SLADE PUMP PACKING

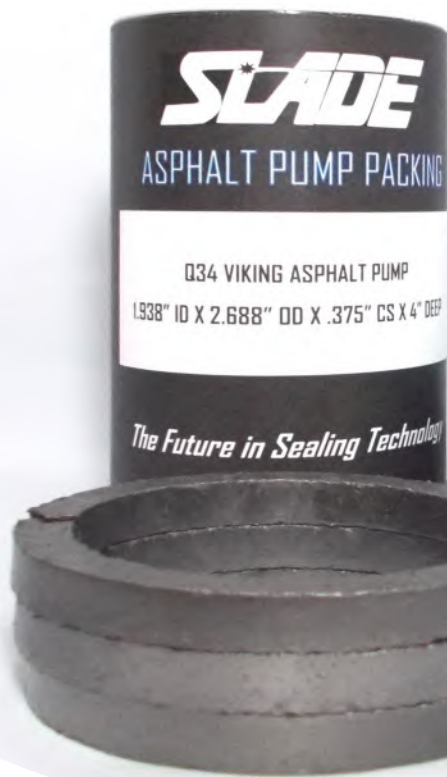

OPERATES LEAK FREE!

COMMONLY USED FOR:

- ASPHALT SHINGLE MANUFACTURING
- TRANSFER STATIONS
- EMULSION PLANTS AND MORE..

DESIGNED FOR ASPHALT PUMPS

Distributed By:

WWW.SLADE-INC.COM

181 CRAWFORD RD • STATESVILLE, NC • 704-873-1366

SLADE



NO MORE
MESSY
CLEAN
UP!



WHY SLADE?

Conventional Packing must leak to provide lubrication and prevent heat buildup.

Slade is different. Slade is capable of running leak free because the graphite provides the needed lubrication and does not insulate heat.

Do you currently use sand, lime, buckets or other means to help clean up the leakage from your asphalt pumps? **Slade Asphalt Pump Packing Sets are designed to run leak free.** No more messy clean up, and no more wasted man hours cleaning up packing leakage.

YOUR # 1 CHOICE FOR ASPHALT PUMP PACKING

PACKING SET DESIGN

SLADES UNIQUE DESIGN HELPS PROVIDE STABILITY TO THE SHAFT, GIVING YOUR BEARINGS ADDED LIFE



PCK COMPRESSION TOOL:

USED TO ENSURE PROPER INSTALLATION OF EACH SEALING RING

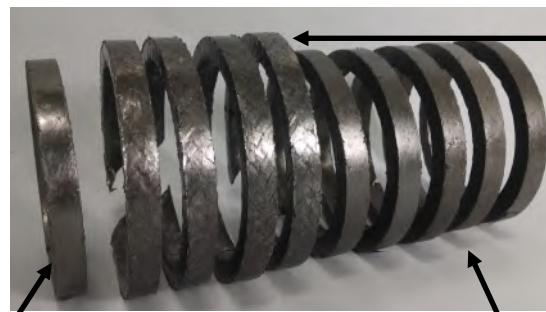

GRAPHITE TREATED BRAIDED COPPER

ALLOY: THE FIRST RING WILL REDUCE THROAT CLEARANCES, PREVENTING PACKING EXTRUSION INTO THE PUMP.

SEALING RINGS EACH SEALING RING IS MADE OF EXPANDED GRAPHITE REINFORCED CARBON FIBER. THESE RINGS ARE ABLE TO TRANSFER HEAT, COAT, AND PROTECT THE SHAFT WHILE PROVIDING LEAK FREE SERVICE.

SPACER BUSHING RINGS: THE SPACER BUSHINGS ARE THE SAME GRAPHITE TREATED BRAIDED COPPER ALLOYS USED AT THE THROAT. THEY REDUCE THE AMOUNT OF PACKING RINGS NEEDED BY FILLING IN EXCESS SPACE. THIS REDUCES FRICTION, HEAT, AND IMPROVES SEALABILITY. THE BRAIDED DESIGN ALLOWS REMOVAL OF A PACKING HOOK OR PACKING SCREW.



181 CRAWFORD RD
STATESVILLE, NC · 28625
WWW.SLADE-INC.COM

SLADE

SOOT BLOWER PACKINGS

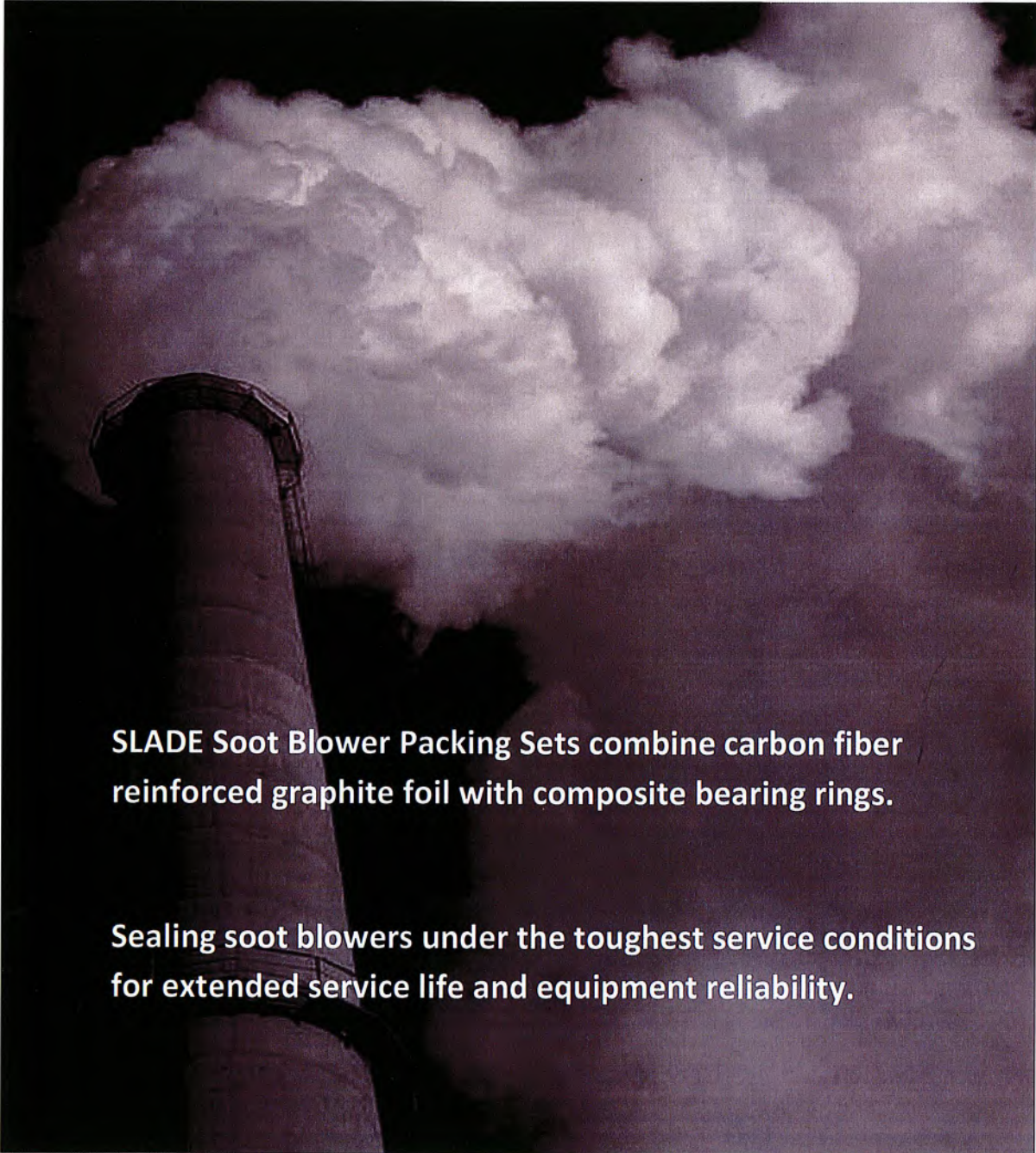

SLADE Soot Blower Packing Sets combine carbon fiber reinforced graphite foil with composite bearing rings.

Sealing soot blowers under the toughest service conditions for extended service life and equipment reliability.

SLADE SOOT BLOWER TECHNOLOGY

Slade Technology offers the best, most reliable Soot Blower Seals

HOW?

Self Lubricating: Graphite Foil Sealing Rings lubricate by filling pits, pores, scratches & machine marks with a micro finish of graphite.

High Density: No voids to trap condensed steam. High density carbon fiber reinforced graphite foil prevents the formation of condensed steam pockets during the cool-down which eliminates the destructive effect of rapidly expanding steam during heat-up.

Lubricated Bearing Support: The bearing surface formed by the graphite composite supports the feed tube when in cantilevered positions.

Deployment of gland stress: Deployed where its needed the most! The graphite/alloy rings deploy gland stress where it is needed most, at the leading edge of the first seal ring.

Easy to Install: The rings are all made to easily fit the stuffing box geometry.

High Ductility: The high ductility of alloy rings provide better run-in at start up.

No extrusion: The alloy/graphite bearing rings prevent extrusion of the packing rings. The confinement maintains structural & dimensional integrity.

Low thermal expansion: Reduces "sticktion", low thermal expansion of the alloy/graphite composite protects the feed tube surfaces from unnecessary friction.

Sacrificial bearing surfaces: Make the sacrifice for you instead of your equipment.

Alloy/graphite composite rings: Protects the feed tube surfaces to reduce wear, platelets of a Slade solid high temperature lubricant impale themselves on micro-jagged surfaces to prevent tearing of the packing sets.

More wear resistant: By combing alloy/graphite composite bearing rings with the latest in solid high temperature lubricants, the packing sets last longer

...and so does your equipment!

Tests have proven the extended life of Slade Soot Blower Packing Sets with minimal wear and less amperage - even in extreme conditions outside typical usage.

Slade's Soot Blower Set
Shown With Liveload Springs

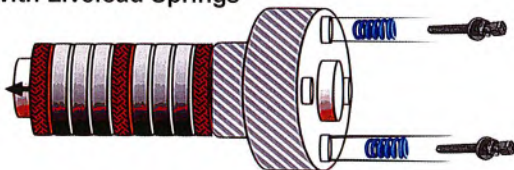

Ask for Slade's Packing
Compressor Kits

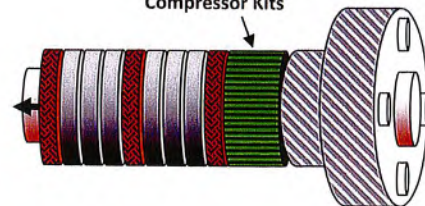

181 CRAWFORD ROAD STATESVILLE, NC 28625

Tel: 704-873-1366 / Fax: 704-873-1399

SLADE Inc.

Website: www.slade-inc.com Contact: Sales@slade-inc.com

WAY-2-SEAL

Manufactured by **SLADE**



WAY - 2 - SAVE

WAY - 2 - LOWER EMISSIONS

WAY - 2 - REDUCE AMPERAGE

WAY - 2 - SEAL

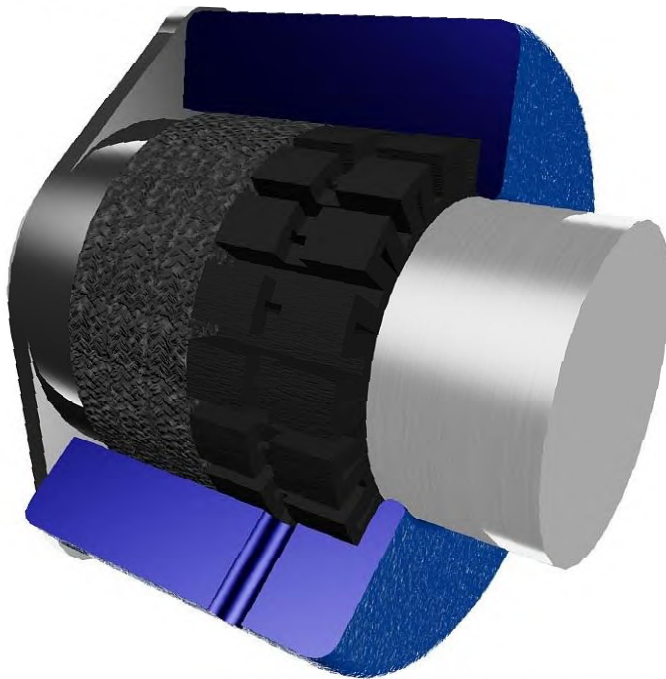

**Contact SLADE
for
standard sizes
and
availability**

THE WAY-2-SEAL

- ELIMINATES THE NEED FOR A LANTERN RING
- REDUCES THE AMOUNT OF PACKING REQUIRED
- LOWERS THE AMPERAGE NEEDED TO RUN THE PUMP



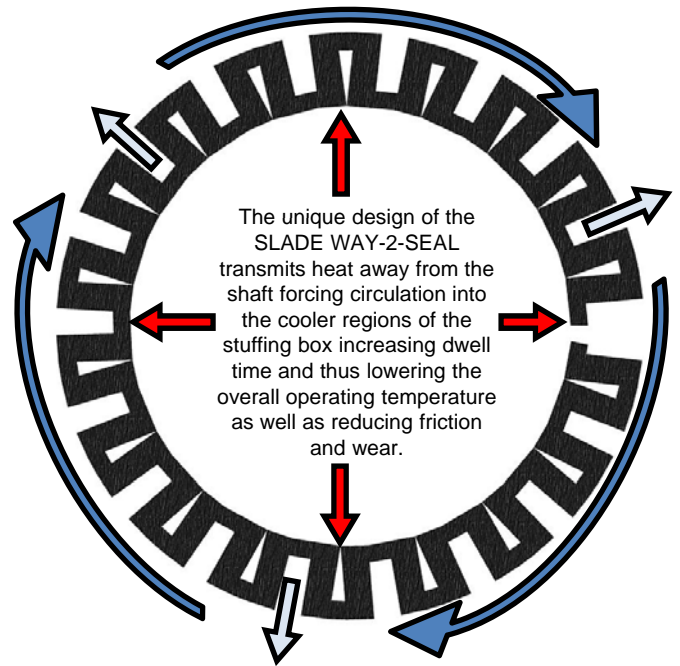
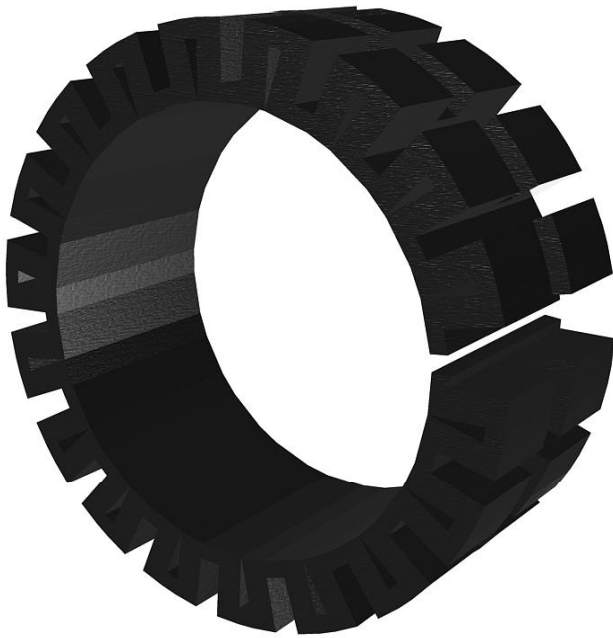

HOW CAN THE WAY-2-SEAL SOLVE YOUR SEALING PROBLEMS ?

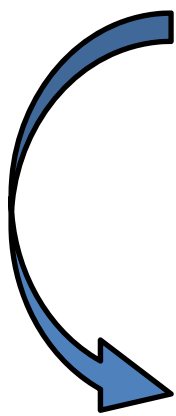

- COOLING BENEFITS REDUCE FRICTION AND WEAR
- EXCELLENT FOR SLURRY PUMP APPLICATIONS
- ELIMINATES THE NEED FOR LANTERN RINGS AND EXPENSIVE MACHINED BUSHINGS
- CAN BE USED IN VALVES TO SHORTEN THE STUFFING BOX AND REDUCE THE NUMBER OF PACKING RINGS
- EXTREMELY SIMPLE INSTALLATION
- ABLE TO WITHSTAND TEMPERATURES UP TO 315°C / 600°F
- CAN EFFECTIVELY BE USED TO LOWER EMISSIONS IN VALVE APPLICATIONS
- CAN BE MADE TO FIT ANY SIZE SHAFT AND STUFFING BOX
- RESISTANT TO THE MOST ABRASIVE MEDIAS
- GREATLY REDUCES FRICTION AND AMPERAGE DRAW
- TAKES ADVANTAGE OF "DELTA P" BENEFITS
- CAN BE RUN FLUSH FREE IN NON-ABRASIVE MEDIAS

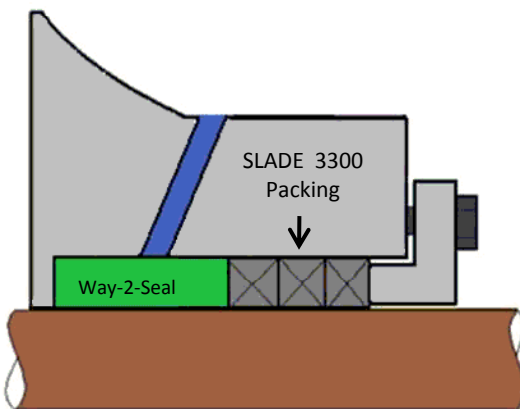

TYPICAL SLURRY PUMP ARRANGEMENT

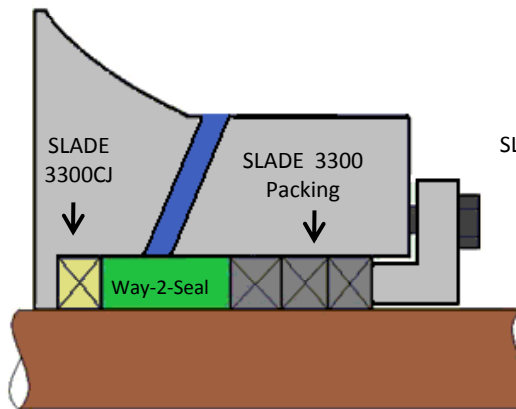

OPTIONAL SLURRY PUMP ARRANGEMENT

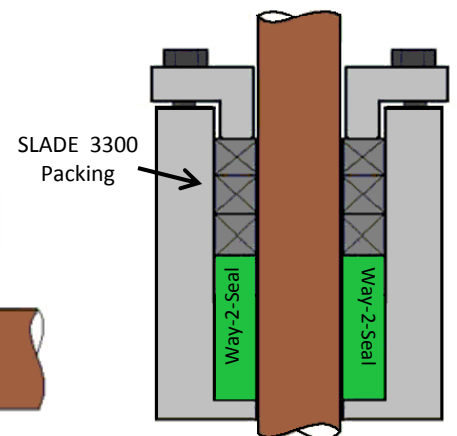

VALVE ARRANGEMENT

For pricing information contact:

INSERT DISTRIBUTOR
LABEL HERE

SLADE

181 Crawford Rd. Statesville, NC 28625
 Website: www.slade-inc.com
 Email: sales@slade-inc.com
 Phone: 704-873-1366
 Fax: 704-873-1399

REDUCE the number of sealing rings in the stuffing box.

REPLACE expensive mechanical seals.

AVOID dismantling the pump.



DSS Spacer Bushings

(Rotational Pump Services)

The bushing comes ready to install: split and hinged

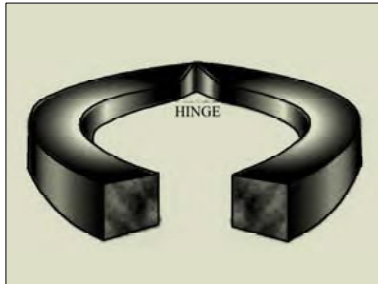

The DSS Spacer Bushing System enables:

- (1) Timely and simplified installation, avoiding the dismantling of the pump.
- (2) Reduction of the number of sealing rings in the stuffing box for a tighter seal.
- (3) Replacement of expensive mechanical seals.
- (4) Removal of flush water in specified applications.

Densely die formed bushing of braided graphite yarns; each yarn reinforced with 304 SS Foil.*

Contact the Factory for standard sizes.

*For special services, ask for Vapor Deposited Rings or Brass Reinforced.

Services (Contact Factory):
Temperatures: up to 1400°F (760°C)
Pressures: up to 4500 psi (310 bar)
ph: 4-10

For flush free service, plug the flush port & remove the lantern ring

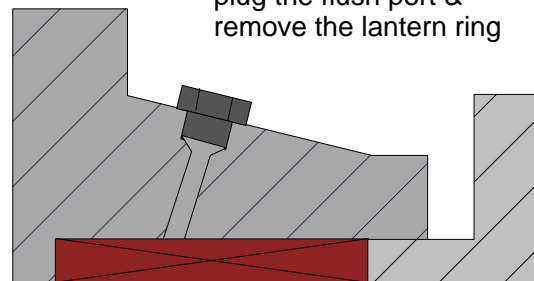

Use DSS Spacer Bushings with Slade 3300G Sealing Rings. Contact the factory for stuffing box configurations.

SLADE

181 Crawford Road * Statesville, NC 28625
www.slade-inc.com * sales@slade-inc.com
Tel: 704-873-1366 * Fax: 704-873-1399

Distributed by:

A Permanent Solution for Deep Stuffing Boxes

- > REDUCE the number of sealing rings in the stuffing box.
- > REPLACE machined carbon bushings as spacers.



Enviro-Foil Spacer Bushings

(Valve Services)

The bushing comes ready to install: split and hinged

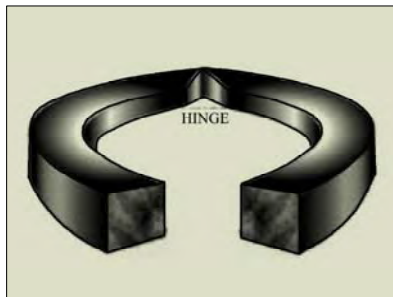

The Enviro-Foil Spacer Bushing System enables:

- (1) Timely and simplified installation.
- (2) Reduction of the number of sealing rings in the stuffing box to improve sealing performance.
- (3) Replacement of machined carbon bushings which may shatter.

Densely die formed bushing of braided graphite yarns; each yarn reinforced with 304 SS Foil.*

*For special services, ask for Vapor Deposited Rings or Brass Reinforced.

Services (Contact Factory):
Temperatures: up to 1400°F (760°C)
Pressures: up to 4500 psi (310 bar)
ph: 4-10

SLADE

181 Crawford Road * Statesville, NC 28625
www.slade-inc.com * sales@slade-inc.com
Tel: 704-873-1366 * Fax: 704-873-1399

Distributed by:

Using more than 5 rings of packing reduces the sealing capability of valve packings (ref: EPRI - Electrical Power Research Institute).

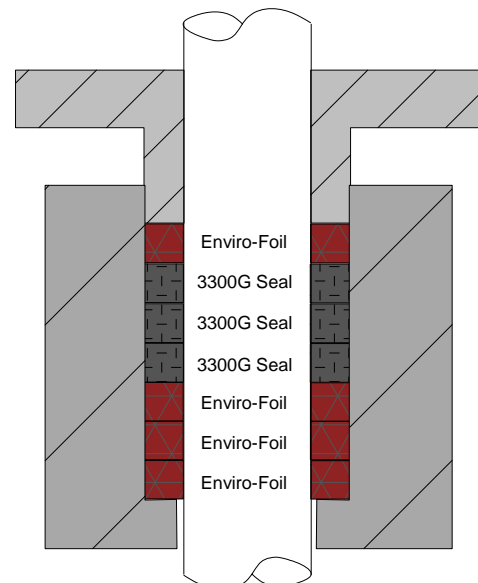

Contact the Factory for standard sizes and stuffing box configurations.

***Packing* COMPRESSOR KIT** *by SLADE*

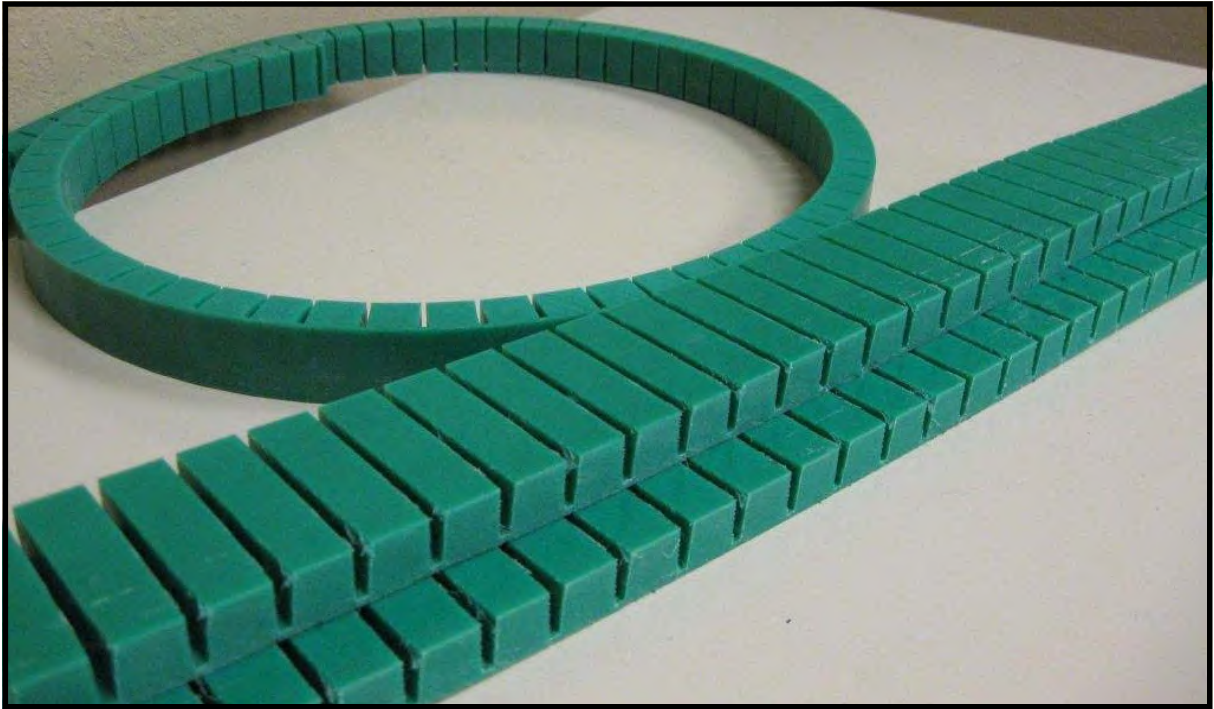

- ◆ **Coil or flatten for ease of storage**
 - ◆ **Cut to length on site**
 - ◆ **Choose from many cross sections**
-
- **To achieve PEAK PERFORMANCE, properly compress packing during installation.**
 - **To achieve PROPER COMPRESSION, use the SLADE *Packing* COMPRESSOR KIT!**

SLADE



Place PCK as shown to compress each ring into the stuffing box.



For small rings ONLY, the PCK may be placed as shown.

APPLICATION INSTRUCTIONS:

1. Cut the appropriate compressor (determined by packing cross-section) to the correct length for the circumference of the shaft/stem.
2. Install one ring of packing and use the compressor(s), in conjunction with the packing gland, to compress the packing to the proper compression ratio (also can be determined by torque factors).
3. **REMOVE Compressor(s)** (Compressors are easily removed with the assistance of two packing hooks).
4. Repeat process until stuffing box is filled.

Combinations of different width compressors can be used, determined by depth of stuffing box. For larger diameters, you may bend the strips toward the slotted side, and for smaller diameters you will need to bend the strips away from the slotted side.

AVAILABLE SIZES:

1/4" x 1", 1 1/2"	1/2" x 1", 2", 3"
5/16" x 1", 1 1/2"	5/8" x 1", 2", 3"
3/8" x 1", 1 1/2"	3/4" x 1", 2", 3"
	7/8" x 1", 2", 3"

Note: All kits are 48" long and 1/32" under nominal thickness for ease of installation.

SLADE

181 Crawford Rd. Statesville, NC 28625
Website: www.slade-inc.com
Email: sales@slade-inc.com
Phone: 704-873-1366
Fax: 704-873-1399

Pyro-Tex Gasket by Slade, Inc.

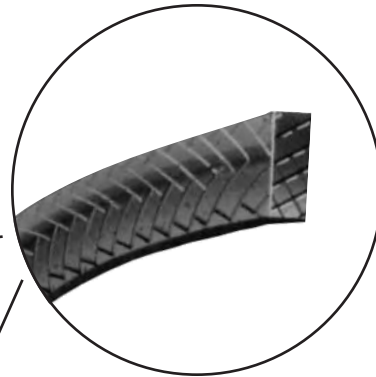
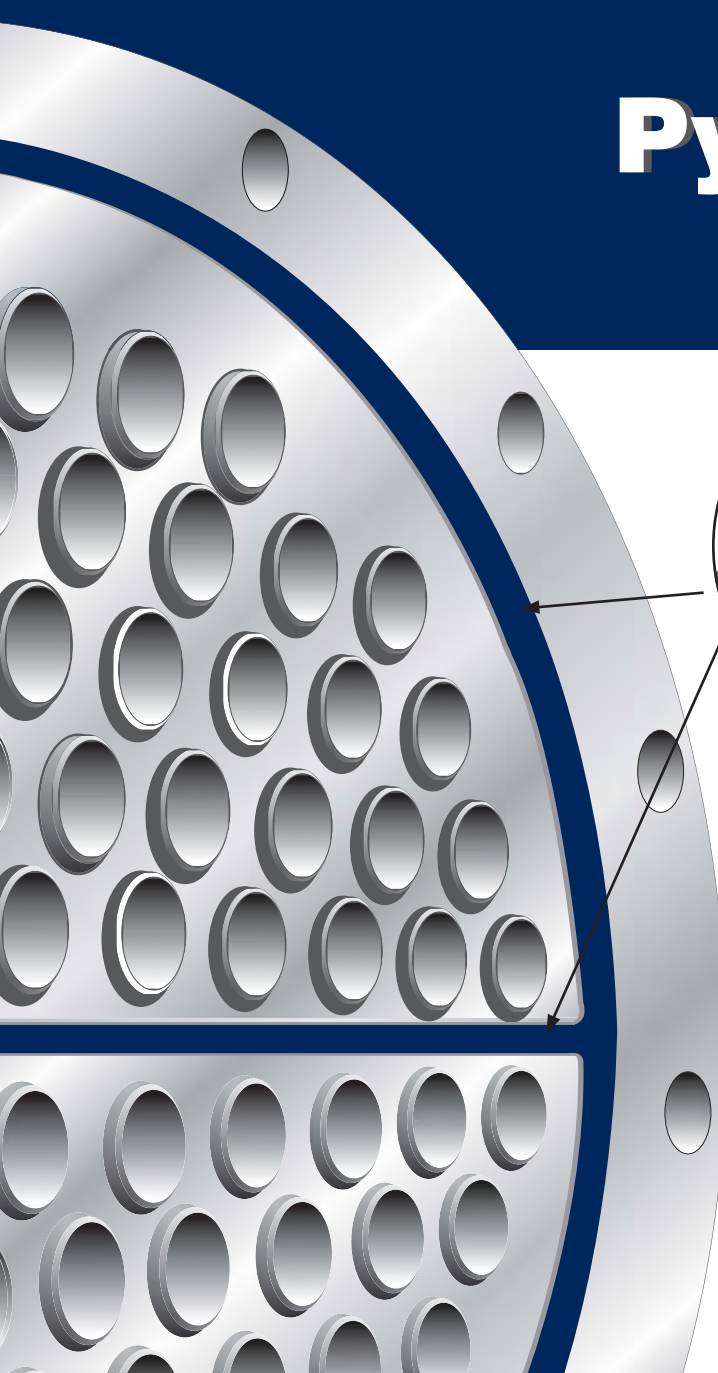

Blue shading represents gasket material after compression. A homogeneous mass forms at joints when tightly compressed.

SERVICES:

Temperatures*: up to 1800°F/1000°C

Pressures: up to 3500 psi/241 bar (Standard style)
up to 4500 psi/310 bar (HP style)

pH range: 0-14, except strong oxidizers

* Contact factory for applications over 1000°F/538°C



Packaged on convenient spools:
25 ft and 50 ft lengths
(8 m and 15 m lengths)
(Special sizes available)

Tube end of Shell & Tube Heat Exchanger

Slade's Self-Forming Gasket eliminates the need to remove the tubes from the Shell

Shell & Tube Heat Exchanger, cross-sectional view

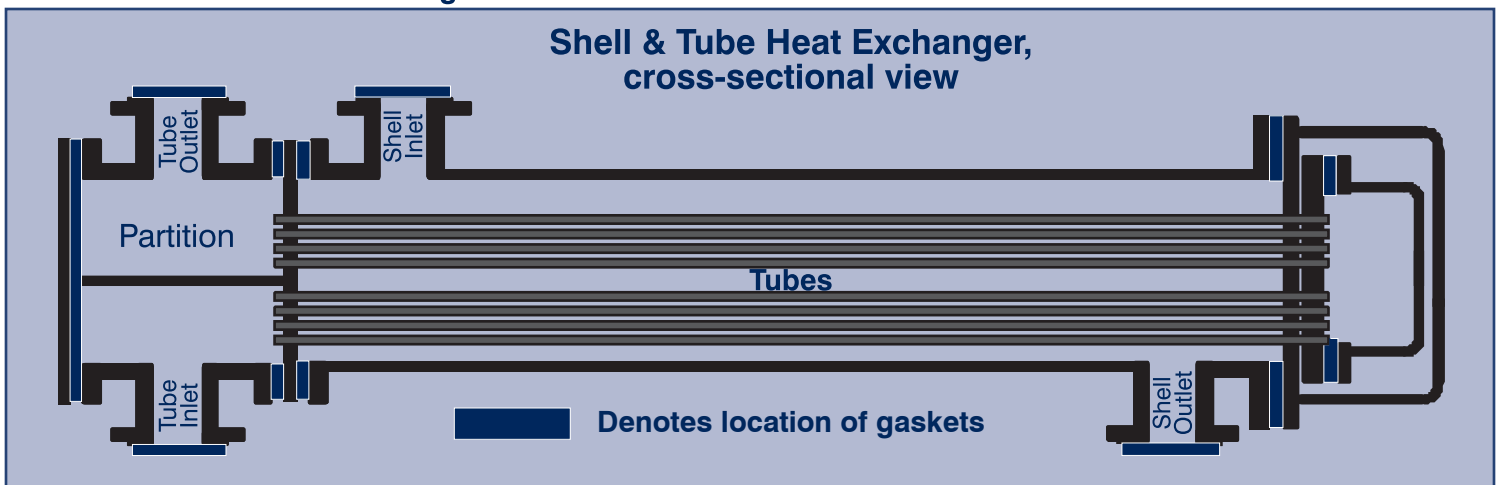

Denotes location of gaskets

Pyro-Tex Self-Forming Gasket



Installation Instructions:

1. Skive cut (on a bias) the end joints for cross sections 5/16" and up. Standard cut and overlap the smaller cross sections.
2. Apply adhesive to the flat side and all joints of the Pyro-Tex and allow to dry until tacky.
3. Firmly seat gasket, pressing it in place as you work it around, overlapping the joint, as shown.
4. For rib applications, overlap each end of the rib with the surrounding gasket, as shown.
5. Firmly press joints together.



SKIVE CUT

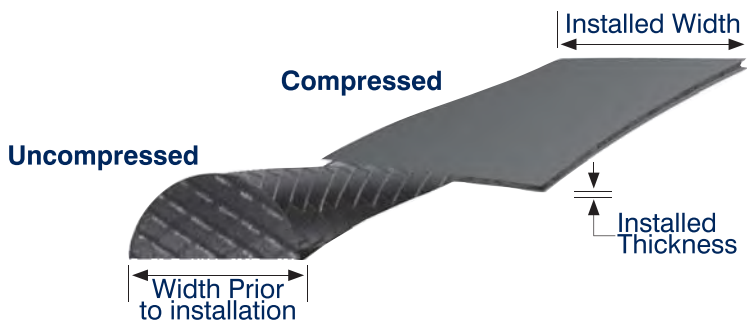
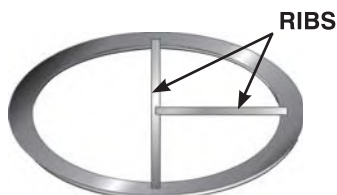

Installation Example: Tongue & Groove

Before Compression
Select a suitable size.
Adhere to groove.

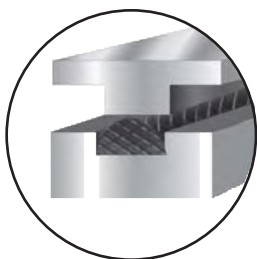

After Compression
The compressed thickness (A) should be 0.070" to 0.090".

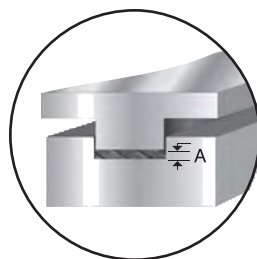

Style: HP

For High Pressure

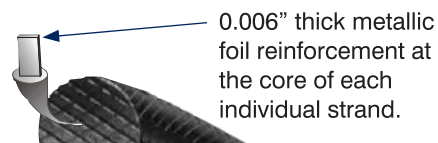

0.006" thick metallic foil reinforcement at the core of each individual strand.

Style: Standard

For Standard Pressure

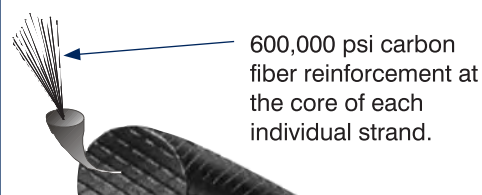

600,000 psi carbon fiber reinforcement at the core of each individual strand.

Size:
(nominal)
inches

Installed Width:
(approximate)
inches (mm)

Widths given for flat-faced flanges only

Standard Square

1/8"	0.250	(6.4)
3/16"	0.375	(9.5)

Standard Semi-round

1/4"	0.420	(10.7)
5/16"	0.500	(12.7)
3/8"	0.600	(15.2)
1/2"	0.900	(22.9)
9/16"	1.000	(25.4)
5/8"	1.250	(31.8)
3/4"	1.750	(44.5)

Standard Rectangular

3/16" x 1/8"	0.260	(6.6)
1/4" x 1/8"	0.370	(9.4)
5/16" x 3/16"	0.590	(15.0)
3/8" x 3/16"	0.700	(17.8)
1/2" x 3/16"	0.860	(21.8)
5/8" x 1/4"	1.350	(34.3)
3/4" x 1/4"	1.560	(39.7)
1" x 1/4"	2.000	(50.8)

Contact Factory for Technical Data

SLADE Inc.

Distributed by:

181 Crawford Road • Statesville, NC 28625 • USA
Website: www.slade-inc.com • Email: sales@slade-inc.com
Tel: 704-873-1366 • Fax: 704-873-1399

The PYRO-TEX WOVEN GASKET SHEET

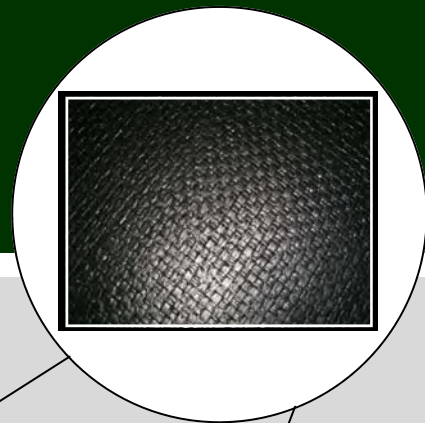

Available in sizes as large as
80" x 160" sheets

Contact **SLADE**
for
Installation Instructions



*Individual Graphite Foil Weaving Yarn
is
Reinforced
with Stainless Steel Strips*

*Yarns are then
Woven*

*Woven Compressed
Gasket Sheet is then
Rolled
into Cardboard Tubes for Shipment*

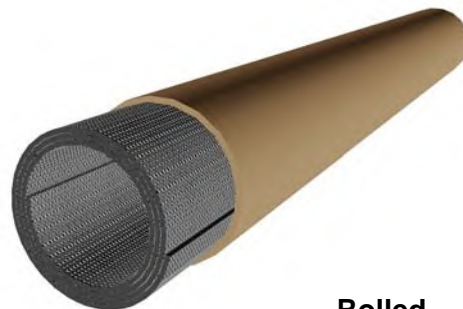

**Rolled
for Shipment**

SLADE Inc.

*

www.slade-inc.com

*

sales@slade-inc.com

PYRO-TEX GASKET SHEET

Services:

Up to 4500 psi/310bar
Up to 1400°F/1000°C*

* Contact factory for application suggestions, especially for high pressures and temperatures over 1000°F/538°C. As the operating temperature increases, the pressure limit of the gasket decreases.



Applications:

Badly oxidized flange surfaces
Ring & Full Face
Manhole & Handhole
Diesel Exhaust Flanges
Turbine Cross Over
Heat Exchangers

Properties:

Compressibility: 34% (T_{room} @ 5000 psi)
Recovery: 6% (DIN 28090-2)
Qmin (0.1 mg/m/s): 20 Mpa (2900 psi)
Qmin (0.01 mg/m/s): 35 Mpa (5000 psi)
Creep Deformation*: 70% ($T=300^{\circ}C$ & $500^{\circ}C$)

* See explanation below

m = 4

y = 3190 psi

- ◆ Eliminates shipping pallets: Gasket Sheets individually packaged in 3" cardboard tubes
- ◆ Takes physical abuse
- ◆ Die cut or shears to shape, do NOT use circle cutters
- ◆ Surface nodules promote flexibility and flow into oxidized surfaces & scratches
- ◆ Eliminates spiral leak path of spiral wound gaskets
- ◆ Layering of sheets allows for greater thicknesses
- ◆ Available in sizes as large as 80" x 160" sheets
- ◆ Single sheet thickness: nominal 0.075"

Contact the factory for Installation Instructions.

* **Conclusions on CREEP DEFORMATION:** results as performed by Dr. M. Gawlinski and Dr. K. Podkomorzy: "In spite of high level of compressibility and low elastic recovery, Pyro-Tex distinguishes itself with a high level of tightness. This paradox can be explained in the following way:

- (1) elastomer, which covers external gasket surfaces, adheres well with flange surfaces at the definite contact pressure value and temperature. The adherence is so effective, that the leakage between gasket surfaces and flanges surfaces is not possible,
- (2) elastomer doesn't penetrate into the gasket material and thanks to that, its middle part preserves some elasticity. Thanks to that, material displacement in the radial and circumferential direction is possible. The structure of the steel strips and expanded graphite makes easy this displacement,
- (3) decrease of the gasket thickness by more than 50% of its initial thickness leads to density increase in the middle area of the gasket and to the decrease of the leakage through the materi-

According to the BHR Group report, *Development of Gaskets Made from Expanded Graphite* by M. Gawlinski and J. Blachura (given at the Sealing for Pollution Prevention and Control 18th International Conference on Fluid Sealing in Belgium), the Pyro-Tex Woven Gasket

- (1) maintains a superior tightness over other graphite gaskets during temperature cycling due to its adherence to the sealing surface;
- (2) operates with high tightness due to the low tangential resistance at compression. Thus, a larger than typical compression set, due to the presence of a nitrile rubber/graphite surface with nodules, is not a deterrent to its sealing capabilities.

181 Crawford Road
Statesville, NC 28625
www.slade-inc.com

SLADE

Tel: 704-873-1366
Fax: 704-873-1399
sales@slade-inc.com

The above data, collected from in-house testing, field testing, and field applications, is subject to change without notice and must be used for examination ONLY. Contact the factory for suggestions on each application. Each application must be independently tested for safety and suitability. Failure to independently test can result in property damage and/or personal injury. 2012

Patented Valve Packing



FIRE SAFE

*Slade Braided Graphite Foil
API Fire Test Certified*

**API 589 First Edition
API 607 Fourth Edition**

Tested by Southwest Research Institute
Witnessed by 3 EXXON Engineers

Performed under American Petroleum Institute grant

Temperatures reached 1876°F/1030°C
Exceeded API requirements by 95%

No die-forming or end rings required

Valves containing flammable fluids may be at risk during a fire if packages are not fire safe and tend to shrink from heat...

No Live Loading Required.

**SLADE Patented Packings
rated FIRE SAFE**

SLADE Inc.

181 Crawford Rd., Statesville, NC 28625
Tel: 704-873-1366 Fax: 704-873-1399

www.slade-inc.com



EMISSION SAFE

*Slade Braided Graphite Foil
USA Emission Standards Exceeded*

Exxon Emission Report

Using PERF procedures & standards...Slade braided packing outperformed standard die-formed graphite ribbon rings by 74%.

Corpus Report

Performed by a major petroleum refining company...96% of the 325 test reported 0 ppm emissions for Slade braided packing using EPA Ref. Method 21 procedures.

Cambridge Report

Major US Refinery reports on 282 field installed tests of Slade braided packing: 99% were below the 500 ppm goal.

(56% were 0 ppm: 96% were below 65 ppm).

Call Slade to request a report.

Approved for sealing VOC by Exxon, Shell, Chevron, Dupont, Eastman Chemical & other companies.

**Slade 3300G for Containment
of FUGITIVE EMISSIONS**

Distributed by:

SLADE



Case Histories

181 Crawford Rd. Statesville, NC 28625

Website: www.slade-inc.com

Email: sales@slade-inc.com

Phone: 704-873-1366

Fax: 704-873-1399

Power Generation

Location: West Virginia

Date: February 2003

Slade Rep: Dynamic Sealing Systems LLC

Application: PG101; Worthington ash handling pump with 5" shaft.

Problem: The pump had a severely worn shaft causing it to leak onto the floor. This was not only messy but was a safety issue.

Solution: Slade 3300CJK was used at the throat followed by Slade 3300G. The packing was compressed using the gland per Slade installation instructions causing it to conform to the worn shaft allowing for a leak free seal. The shaft was able to be reused, the flush was removed, and repacks have been significantly reduced.



Location: Ohio

Date: February 2003

Slade Rep: Dynamic Sealing Systems LLC

Application: PG102; Raw Water Strainer with 7 1/2" shaft located in a coal-fired power plant in Ohio.

Problem: The shaft of the strainer is worn badly causing it to leak water onto the floor and create safety issues.

Solution: Slade 3300CJK was used at the throat followed by Slade 3300G packing die formed and compressed around the shaft. The flush was able to be eliminated saving the plant money and the safety problems involving a slippery floor no longer exist. The same plant replaced 3 other strainers with Slade packing as well since they had such great success with the original application.



Location: Western Pennsylvania

Date: October 8, 2011

Industry: Power Plant

Slade Rep: Dynamic Sealing Systems

Application: PG103; Split case Ingersoll-Rand cooling water pumps, three in a row

Situation: Customer was using a competitor's material for years with no success. The pumps were on a closed loop water system that they had to add a chemical, costing \$80,000 a year, to keep the algae out of the water.

Solution: Applied 7 rings of 3300G, after 10 minutes the pumps were running leak free. **Outcome:** Pumps are running with just a small drip. The plant has told me they have saved about \$100,000 in chemical costs since the installation of Slade material in July 2009.



Power Generation

Location: Long Island, NY
Date: 2009
Industry: Power - Utilities
Slade Rep: Spacely Sprockets
Application: SA104; Valves

Situation: Every 2-3 weeks, valves leaked & were repacked with material they had always been using.

Solution: Slade's 3300G 5/8"

Outcome: The Company could not believe the Slade material was still holding 6 months later!



Location: Chennai - India
Date: October 13, 2011
Industry: Nuclear Plant
Slade Rep: R. Sekar
Application: PG104; HP Process Water Pump

Situation: Because of Isolation problem, mechanical seal failure is continuous

Solution: Packed with three rings of 3300G and ensured no issues of failure & isolation of equipment

Outcome: Running Trouble Free



Location: Copenhagen
Date: 2011
Industry: Energy
Slade Rep: Botech Seals
Application: PG106; Waste Water Pump – DN1200

Situation: An old pump with leakage and unknown packing being used.

Solution: Installed one 3300CJ and four 3300C rings.

Outcome: Very Satisfied Customer



Power Generation

Reports Received: October 3, 2011

Slade Representative: Rotaserv

Application: PG105; Multiple locales in Colorado and Texas using Westinghouse Steam Turbines.

One Solution fixes all:

Install Pyro-Tex Sheet Gasket

Situation 1: Multiple customers were using competitor material which was carbonizing & causing premature failure.

Situation 2: Multiple customers were still using Asbestos sheet gasket and wanted a safe alternative that would meet the application requirements.

Situation 3: Customer using spiral wound gaskets encountering difficulty during installation, required making adapters to accommodate, material was still causing premature failure.

Situation 4: Customer was using a corrugated metal graphite coated gasket.

Outcome: Continual service without failure of gasket between outages on all applications.



Slade Recommends: See our brochure on Pyro-Tex Woven Gasket Sheet material for more information or e-mail us at sales@slade-inc.com

Pulp & Paper Processing

Location: South Carolina

Date: April 2007

Slade Rep: Bryan Kern

Application: PP101; Side Entry Lightnin Agitator model 5VSAG. 6-1/2" shaft and 8" bore, used to mix bleached stock.

Problem: Heavy leakage in a high traffic and highly visible area. This was a safety hazard due to the slippery nature of the stock. A loss of 2-1/2 gallons a minute at a consistency of 2.63% which translated to \$800 a day.

Solution: The throat bushing, which also acted as a lantern ring with a flush, was left in place. Two DSS rings were installed, followed by three 3300C rings compressed individually, rotating the shaft after each ring was compressed. This packing is still functioning properly after 2 years with only a slight drip.



Location: Georgia

Date: May 2006

Slade Rep: Jake Rojas

Application: PP102; Worthington Double-ended Pump

Problem: The sleeve and stuffing box on this pump were extremely worn causing it to pump seal water so badly that you could not get within 20 feet of the pump without getting soaked. Conventional packing just couldn't seal properly.

Solution: The flush was eliminated and 5 rings of 3300G were firmly (not fully compressed); this allowed it to leak slightly at startup. With minor adjustments (two flats wait twenty minutes) in order to stop leakage. This prevents the trapping of moisture, heating to steam and blowing out the packing.



Location: Georgia

Date: May 2006

Slade Rep: Jake Rojas

Application: PP103; Warren 14x14x22 White Water Pump

Problem: Severe sleeve wear causing the previous packing to not seal properly. Replacement of the sleeve is costly and the heavy leakage causes problems with the bearings and motor.

Solution: Two rings of 3300CJ were butt cut with small gaps lined-up at 12:00 position to allow flush water to pass through followed by a Lantern ring with flush on and 3 rings of 3300G. A step size larger packing was used due to the severe wear on the sleeve.



Pulp & Paper Processing

Location: South Carolina

Date: May 2006

Slade Rep: Jake Rojas

Application: PP104; Turbo Separator with slow turning 10" shaft used to grind paper, cardboard, staples, and many other highly abrasive materials.

Problem: Flush water pressure varies causing packing to run dry and burn up. This caused a bad leak which covered the area in stock.

Solution: One ring of 3300CJK was installed at the throat followed by 5 rings of 3300G. The rings were installed with out heavy compression using gland to push the rings to the bottom of the stuffing box and snug everything up. The bolts put on hand tight plus two turns of a wrench. After start-up one adjustment was made and the Separator has been running great since.



Location: South Carolina

Date: February 2007

Slade Rep: Jake Rojas

Application: PP105; Hydro-Pulper with a 32" shaft used to grind bales of paper, cardboard, staples, and many other highly abrasive materials.

Problem: Current packing was only lasting 2 months or less with heavy leakage due to the high volume of material as well as trash and wear in the system.

Solution: One ring of 3300CJ was installed followed by 3 rings of 3300G that were compressed using hydraulic jacks because of their size. Slade packing has lasted over 4 times longer than the previous supplier's.



Location: Georgia

Date: May 2006

Slade Rep: Jake Rojas

Application: PP106; Goulds 3175 14x14x22 stock pump with 4-3/4" sleeve and 5-3/4" bore.

Problem: The sleeve was worn causing traditional packing to leak stock everywhere. In addition to this, replacement of the packing was needed every few weeks due to the wear.

Solution: Two rings of 3300CJ were butt cut with small gaps lined-up at 12:00 position to allow flush water to pass through followed by a Lantern ring with flush on and 3 rings of 3300G. The flush was accidentally left off at initial start-up and the packing still performed flawlessly.



Pulp & Paper Processing

Location: Ontario

Date: February 2008

Slade Rep: York Fluid Controls

Application: PP107; Allis Chalmers Repulper Centrifugal Pump, 10x8", 100HP, 1200RPM

Problem: The pump was leaking substantially through the gland causing all the graphite to be washed off of the current packing, Chesterton 1730.

Solution: 3300G was used and even with extensive water hammer the leak on the pump is only 2 drops per minute which could lower with future adjustments. This plant is currently using Slade packing in 3 applications and plans to expand that number even more in years to come.



Location: Ontario

Date: March 2008

Slade Rep: York Fluid Controls

Application: PP108; pulp and paper refiner, process inline; 250HP, 1200RPM.

Problem: An extensive leak had washed away the current packing, Chesterton 7130, to the point that a 15 GPM loss was occurring. The lifetime of the packing was very short due to this as well as poor design.

Solution: 3300G was used in combination with a Lantern ring. The flush water has been reduced greatly and only a very slight drip is present. Slade has outlasted the former packing by over 8 times and all 3 refiners are planned to be converted to Slade in the future.



Location: India

Date: July 2007

Slade Rep: R. Sekar

Application: PP109; Screw pump of Indian make used to pump a paste like calcium carbonate based material.

Problem: Mechanical seals failed often as well as traditional packing. Sealing water was used in all applications which diluted the chemicals leading to inconsistent paper quality.

Solution: Two rings of 3300CJ followed by three rings of 3300G were installed per Slade's installation instructions. The leaking was reduced to a negligible amount and the packing has lasted for over six months.



Pulp & Paper Processing

Location: Evergreen – Pine Bluff, Arkansas
Date: March 27, 2011
Industry: Pulp and Paper
Slade Rep: Joe Dodson
Application: PP110; Green Liquor Pump – Worthington
Frame IV 2-1/8” Shaft

Situation: Mechanical seals lasting 3-6 weeks. Using AES, double cartridge costing \$3,200 each.

Solution: Installed one 3300CJ, three 3300C and five DSS rings costing less than ¼ the amount, with no flash resulting.

Outcome: Getting double the life, running for 12 weeks or more.



Location: South Korea

Date: 1/14/2014

Slade Rep: ISK

Application: White Stock Pump

Problem: Inferior packing needed replacement rings every 2 weeks. Every install on pump weeks meant money lost on shut downs.

Solutions: Repacked the white stock pump with Slade’s 3300C Pump Packing. No flush is needed.

Outcome: Same Packing has been in use for the past 3 months. “We are very happy with the outcome of our white stock pump. We are planning on using Slade packing for our Hydro Pulper.”

Specialty Applications

Location: Midwest

Date: July 2004

Slade Rep: Lukas Enterprises

Application: SA101; Wemco Centrifugal Pump with hardened steel sleeves

Problem: Bone chips and animal tallow are highly abrasive causing heavy leakage, excessive bearing wear, and frequent repacks. City water is also very costly when used for a flush.

Solution: The Lantern ring was removed and two rings of 3300CJ were used at the throat followed by four rings of 3300G. The pump is now operating totally leak free with a repack interval of one to two years. With a cleaner application even less rings could be used in combination with Slade DSS rings or a bushing.



Location: Virginia

Date: June 2000

Slade Rep: The DELAMAR Company

Application: SA102; Raw influent pump in a waste water treatment facility.

Problem: Conventional packing would not seal this pump correctly and it was in constant need of adjustments and packing.

Solution: One ring of Slade 3300CJ was used at the throat and followed by five rings of 3300G. The pump is now working virtually leak free without a flush. The abrasive fluid and large shaft diameter made this pump difficult to seal with traditional packing but was no problem for Slade's 3300 product line.



Location: Texas

Date: January 2002

Slade Rep: Jake Rojas

Application: SA103; Triplex Reciprocating Ammonia Pump used in chemical plant

Problem: Very noticeable leak at the main gate of the plant producing a heavy ammonia odor. Adjustments had to be made daily and the packing had to be replaced every 3 to 6 weeks along with the very expensive chromium carbide coated plungers.

Solution: A special packing arrangement comprised of Slade 3300K and 3300C packing was used and worked so well that the planned use of a barrier fluid was eliminated. Only minor adjustments are required a few times a year and plunger wear is minimal.

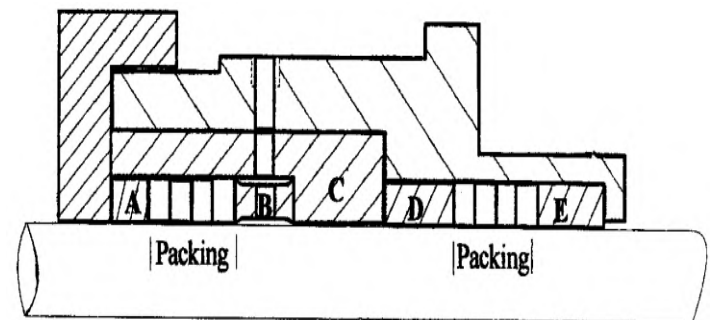

K G G K

K: 3300K
G: 3300G

Specialty Applications

Location: Australia

Date: December 2005

Slade Rep: South Eastern Gaskets

Application: SA104; Purpose built canned pet food sterilization unit with a 6” shaft operating at 130°C, 190kPa, and 4 RPM.

Problem: The Garlock packing that was being used required constant adjustments and would not properly seal. The units operated round the clock so it was imperative that the packing not require any down time from these machines.

Solution: The packing was replaced with 3 rings of Slade 3300G and is operating virtually leak free after over 3 years of use. The packing requires only minor routine adjustments due to the large tolerances in the equipment’s parts.



Location: Blue Island Phenol

Date: July 2011

Industry: Chemical

Slade Rep: Pumping Solutions

Application: JS303; Heat Exchangers

Situation: Wrong metal gasket sizes – needed gaskets right away and didn’t have the time to remake them.

Solution: Slade HPT Pyro-Tex Joint Sealant. Because the gasket is a spooled material, it can be made to fit virtually any size and configuration.

Outcome: Excellent – installed on 4 units



Location: Ontario

Date: July 2011

Industry: Asphalt

Slade Rep: York Fluid

Application: SA105; Viking Q32 & 124 Rotary Gear Pumps

Situation: Terrible leaking through seal with conventional graphite packing – 13 Rings of 3/8” packing.

Solution: Straight replacement, proper installation of 3300C

Outcome: Completely eliminated all leakage and went through road rebuilding season problem free. Has lead to purchasing approval for 22 plants.



Specialty Applications

Location: Hungary
Date: October 7, 2011
Industry: Fertilizer Manufacturing
Slade Rep: Dynoteq - Hungary
Application: SA106; Ammonia Decomposition Reactor

Situation: Leaking head gasket. Previously using competition joint sealant leaking toxic ammonia.

Solution: Slade Pyro-Tex JS HP

Outcome: No leakage, happy customer!



Location: Nebraska
Date: October 2011
Industry: Bio-fuel
Slade Rep: Pumping Solutions
Application: SA107; Conveyor Equipment with material being a cream corn consistency.

Situation: Packing or seal system leaks – dropping into gear box which ends up failing.

Solution: Packed with six rings of Slade 3300G.

Outcome: 15 minute break-in with 100% no leakage, running 8 months with no adjustments.



Location: South Korea

Date: 5/21/14

Slade Rep: ISK

Application: Sap Dryer

Problem: Competitor's packing would only last 2 days causing great frustration and downtime.

Solution: Installed Slade's 3300G. "With Slade two of our dryers have been running for the past 8 months where as previously they only ran for a few days."



Specialty Applications

Location: Florida

Date: 2/1/14

Slade Rep:

Application: N34 & M34 Viking Pumps



Problem: Inferior quality packing needed replacement rings every 2-4 weeks. Typical packing must leak, causing constant cleanup and attention.

Solution: Repack both N34 & M34 Viking Pumps with Slade Asphalt pump packing sets.

Outcome: Train car off loading Viking pump has worked an entire year without the need of adjustment or repacking. NO more leakage, NO more clean up. Eliminated need for constant adjustments. "Slade has turned our most problematic pump into the one pump we never have to think about."

Location: India

Date: 2013

Slade Rep: Nekil

Application: Pump Impeller

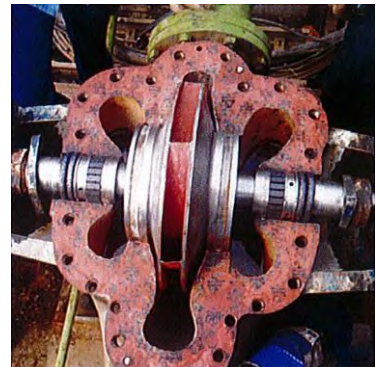
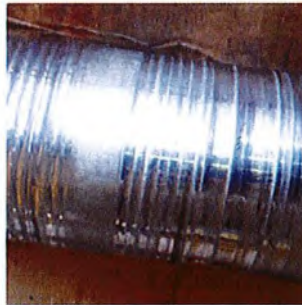

Problem: Sleeve has been severely damaged from inferior packing. Competitor's packing was unusable each time pump was opened up for other maintenance causing extra service Costs.

Solution: Repack Pump Impeller with Slade's W2S spacer bushing and 3300G Pump Packing. Sealing Water Capped off.

Outcome: "This is the first time that our pump packing runs without sealing water and NO leakage out of gland!"

Specialty Applications

Location: South Carolina

Date: 6/24/14

Slade Rep:

Application: Dredge Pump (Sand Slurry)



Problem: Sand is very corrosive and machinery is much worn. Shaft has excessive wear and has dropped 3/8". Customer complained of competitor's packing only lasting 2 months with excessive uncontrollable leakage.

Solution: Installed Slade's 3300CJ and 3300G packing. Compressed individually which raised shaft.

Outcome: Very little to no leakage after 1 year. Only one adjustment made. No additional wear to shaft. "Slade Packing has made our old equipment work like new and more than anything it lasted over a year!"

Location: South Korea

Date: 1/14/14

Slade Rep: ISK

Application: Kraft paper mill



Situation: Issue of stock spewing out causing company to shut down mill refiner due to waste.

Solution: Repack a Kraft mill refiner with 5-3300C Pump Packing Rings. The first 2 rings were butt cut and aligned at 6 o'clock to channel the flush into the product. Tightened up 2 flats and then removed the flush to become leak free.

Outcome: Customer extremely happy with the performance. "A once shutdown mill refiner is now running again thanks to the Slade 3300C Packing."

Steel Manufacturing

Location: Indiana
Date: April 2007
Slade Rep: Lukas Enterprises
Application: SM101; RC Water Booster Pump and Lance Water Cooling Pump

Problem: Conventional packing was prematurely wearing the sleeves requiring the use of hardened sleeves which cost 2 to 3 times more.

Solution: Slade 3300G was used to replace the current packing. Slade packing only requires the use of 304SS non hardened sleeves. This configuration causes virtually no sleeve wear allowing the pump to run longer with less down time. The mill is now able to clean and polish the sleeves instead of replacing them, saving a significant amount of money.



Location: Romania
Date: May 2008
Slade Rep: Inventeq & Flexotech
Application: SM102; Centrifugal water pump operating at 6 bar, 150°C, 3500 RPM, and 9-5pH.

Problem: The high RPM that this pump runs at caused traditional packing to burn quickly which wore the sleeve and made a flush necessary.

Solution: The lantern ring was removed, the flush was closed, and 3300C compressed by 30% was used for packing. After 3 months the pump was still running great with only a few drops of leakage in order to cool the shaft and bearings.



Location: Romania
Date: May 2006
Slade Rep: Dynotech
Application: SM103; Centrifugal slag pump operating at 8 bar, 50°C, and 5-8pH.

Problem: Frequent repacks were needed in this application due to the metal content in the fluid. The sleeve wore very quickly because of this and repacks were costly because of the deep stuffing box (10 rings).

Solution: The lantern ring was removed and 3300C was used as packing. Only 4 adjustments were required in 3 months to keep the pump in leak free operation. This also helped reduce sleeve wear from the lack of metal content entering the stuffing box. The life expectancy of this packing is more than half a year.



Mining Applications

Location: Virginia

Date: February 2003

Slade Rep: Dynamic Sealing Systems LLC

Application: MN101; Warman 12x10 pump with a 7" shaft operating at 624 RPM in a Zirconium and Titanium Dioxide mine.

Problem: Traditional packing was causing excessive wear due to leakage of abrasive fluids. The pump had to be re-packed every 3-5 days.

Solution: Slade 3300G was used to replace the current packing. There was no flush available in this application which is perfectly acceptable when using Slade packing. The pump is now operating leak free and is on a 13 week inspection cycle.



Location: Western Pennsylvania

Date: February 2003

Slade Rep: Dynamic Sealing Systems LLC

Application: MN102; Goulds 5500 with a 3 3/4" shaft pumping a slurry material comprised of 43% solids.

Problem: The current packing was leaking excessive amounts of dirty flush water which is hazardous to the environment and corrosive to the pump and its bearings.

Solution: Two rings of Slade 3300CJK were used at the throat of the pump followed by four rings of Slade 3300G. The shaft was able to be reused and the pump is operating virtually leak free without a flush. The hazards that come with leaking pumps, slippery floors, damaged motors, seized bearings, etc., are now eliminated.



Location: Ohio

Date: February 2009

Slade Rep: Dynamic Sealing Systems LLC

Application: MN103; Warman B-AH lime slurry pump used in a coke plant.

Problem: As with all lime slurry applications, traditional packing has a very difficult job sealing the pump. In this particular pump the packing was needing to be replaced every 2-3 days resulting in excessive down time and tremendous expense.

Solution: Slade 3300CJ was used at the throat followed by 3300G. Only 3 minor adjustments were needed to keep leaking to a minimum, 2-20 drops per second, and the pump has been in operation ever since.



Valves

Location: St. Croix

Date: May 2006

Slade Rep: Joel of Spacely Sprockets

Application: VA101; 495,000 barrels-per-day oil refinery. This refinery operates a 140,000 barrels-per-day fluid catalytic cracking unit capable of turning out 175,000 barrels-per-day of gasoline.

Problem: The maintenance department was looking for a more reliable and easier to replace packing for all of the valves in use at the refinery.

Solution: Slade packing was used to replace all packing in all the valves in the refinery. Slade is not only cheaper than their former packing but it also eliminates scoring of the valve stems from wire inserts and is much easier to replace than other forms of packing.



Location: Pennsylvania

Date: February 2003

Slade Rep: Dynamic Sealing Systems LLC

Application: VA102; Spirax Sarco River Water Strainer with 3/4" shaft.

Problem: Conventional packing has never worked in this application. A steady leak has been present since installation causing a safety hazard.

Solution: Slade 3300G was used to replace all of the packing completely stopping the leak for the first time in 15 years. Slade packing has a much longer life than the previous packing saving the company additional money as well as preventing slippery floors and accidents.



Location: Louisiana

Date: April 2000

Slade Rep:

Application: VA103; numerous OEM valves

Problem: During a seminar on the effects of Teflon on valve stems and stuffing boxes, several manufacturers realized that they were having these problems occur with many of their valves

Solution: The current packing used by these manufacturers, Garlock 1303FEP, was replaced by Slade 3300G and Enviro-Foil rings. 126 valves were packed with Slade in less than 1 month from the seminar and the manufacturers were all delighted with the labeling, packaging, and installation instructions provided by Slade. These valves are in service operating between -20°F-1200°F.



Marine Applications

Location: Ohio

Date: February 2003

Slade Rep: Dynamic Sealing Systems LLC

Application: MA401; Tug fleet on the Ohio River

Problem: A reoccurring stern tube leak on most of the vessels was causing excessive shaft wear, frequent re-packs, and polluting the river with bilge water. No traditional packing was able to improve the situation.

Solution: Slade 3300G packing was used to replace all packing in all of the fleet vessels. The tubes are now leak free and use a spacer bushing to even further reduce the amount of packing required. The pollution has been eliminated and shaft life has been drastically extended.



Location: Virginia

Date: March 2002

Slade Rep: The DELAMAR Company

Application: MA402; Stern tube on Newport News Shipbuilding guard/patrol boat with twin Detroit Diesel V8's with 2 1/2" shafts.

Problem: Conventional stern tube packing requires frequent re-packs, constant adjustments, and still leaks while in service.

Solution: Newport News Shipbuilding now uses Slade 3300G packing in all of their stern tubes because it has proven to be the only packing to successfully handle this application. The packing lasts for years without harming the shaft or needing adjustments.



Location: Virginia

Date: 2014

Slade Rep: The Delamar Company

Application: Exhaust system for a 110 foot Marine craft.

Problem: Quite a bit of thermal shock happens as the temperature can go from ambient to the 1200F degree level in mere seconds with pressures of about 40psi. Also there is a considerable amount of movement of the assembly when the ship is underway

Solution: Installed Slade's Patented Pyro-Tex Gaskets

Outcome: The Slade Pyro-Tex Gasket accommodates the movement of the assembly effortlessly and handles the high temperatures with no trouble. "Slade's Pyro-Tex Gasket is in a class all of its own, it outlives the service life of the rings on our exhaust system."



Sheet Gasket

Location:

Date: June 2006

Slade Rep:

Application: SG301; Vessel sight glass under a slight vacuum withstanding 800°F temperatures needing a seal between a metal frame and 3/4" Pyrex glass.

Problem: Conventional fiberglass gaskets were not able to seal properly.

Solution: A PyroTex sheet gasket was cut to shape with shears and glued in place. The seal was in service over 12 months with no problems.



Location:

Date: June 2006

Slade Rep:

Application: SG302; Standard ANSI carbon steel pipe flange containing steam at 600°F and 150psi.

Problem: A conventional spiral wound gasket was being used but the problems that come with this type of seal can be very troublesome. A spiral wound gasket can be over-compressed or crushed resulting in a gasket that will not seal on a worn or steam-cut flange.

Solution: A PyroTex sheet gasket was die-cut and glued in place on the flange. The joint was tightened to maximum allowable torque and the gasket has been in operation ever since without any problems.



Location:

Date: June 2006

Slade Rep:

Application: SG303; Gooseneck gasket for coke battery withstanding temperatures of 1100°F and pressures from 0psi to a slight vacuum.

Problem: The current gasket, Garlock 9900, was unable to give a satisfactory seal because of the high temperatures of this application.

Solution: A Slade PyroTex sheet gasket was cut to shape using shears and glued in place. The gaskets has since seen over two years of service with no apparent issues.



Sheet Gasket

Location: Malaysia

Date: April 2008

Slade Rep: Mahawaria

Application: SG304; 10" Xanik Valve in a Malaysian power plant.

Problem: The current bonnet gaskets were leaking resulting in critical downtime to resurface the flange faces and replace the gaskets.

Solution: Slade PyroTex Gasket Sheet was used to replace the leaking gasket. The unique design of the PyroTex Gasket Sheet eliminated the need to resurface the gasket saving time and money during installation. The bonnet has preformed leak free since installation.



Location: Texas

Date: April 1999

Slade Rep: Rotaserv

Application: SG305; Crossover Turbine in a coal fired power plant operating at 1000°F and between 300-1000psi.

Problem: The extreme temperatures and pressures seen in these turbines nothing besides an asbestos gasket will work.

Solution: The unique construction of Slade PyroTex Gasket Sheet allows it to replace the older style asbestos gaskets that are currently used in these applications. The PyroTex material can easily handle these temperature and pressure extremities allowing for a more reliable and maintenance free seal.



Joint Sealant

Location: Hungary

Date: May 2005

Slade Rep: Inventeq

Application: JS301; 50 year old gate valve in a coal fired power plant

Problem: After each startup the head gasket was having to be changed in the valves because of heat expansion. The valve was so old and worn that there was a tolerance between 1-3mm in flange groove depth.

Solution: An initial attempt to use Slade semi round PyroTex Standard Joint Sealant was unsuccessful due to the amount of torque required to be used in assembly of the valve. A second attempt was made using Slade 3300G packing which conformed to all of the irregularities in the flange groove and sealed perfectly.



Location: Alabama

Date: July 2004

Slade Rep: Seal Dynamics

Application: JS302; 18" nozzle flange in a steel mill operating at 1800°F

Problem: The spiral wound gasket that was being used was not sealing properly because the flange faces were badly warped. Flatness was out by over 9/16" in some areas.

Solution: Slade 1 1/4" square Standard Joint Sealant was used in this application and has worked perfectly since installation. The large size of the Joint Sealant allows it to conform to all of the uneven areas of the flange. The company was so impressed by the performance of the product and the ease of installation that they also replaced 5 other flange gaskets in the mill.



SLADE



DataSheets

181 Crawford Rd. Statesville, NC 28625

Website: www.slade-inc.com

Email: sales@slade-inc.com

Phone: 704-873-1366

Fax: 704-873-1399

SLADE 3300C Valve and Pump Packing



For flush free pump service with virtually leak free performance, contact the factory for specific recommendations. Used in high pressure heater drain pumps, condensate, boiler feed, recirculation, make-up water, cooling water, auxiliary boiler feed, vacuum, and other water related applications. Commonly used in steam & chemical applications.

Recommended for valve emission containment up to 1800°F/1000°C.

Lifetime warranty for valves¹

HIGH PURITY EXPANDED GRAPHITE PACKING

MANUFACTURER OF YARNS		Slade, Inc.
BRAIDER		Slade, Inc.
TYPE NAME		Slade, Inc.
TYPE NUMBER		3300C
TYPICAL COMPOSITION		
MAIN COMPONENT		Graphite/Carbon
STATE OF MAIN COMPONENT		Vermiculate
DENSITY DIE FORMED (braided: before die forming)	lb/ft ³ (g/cm ³)	65(1.04)
GRAPHITE PURITY	% Weight	99
ASH	% Weight	0.74
INHIBITOR TYPE		Phosphate or Zinc Available
CARBON FIBER per yarn	% Weight	<10
TYPICAL STANDARDS		
CHLORIDE LEACHABLE	ppm	10
TOTAL CHLORIDE	ppm	50
FLUORINE LEACHABLE	ppm	10
TOTAL FLUORINE	ppm	50
TOTAL SULFUR	ppm	560
WORKING PARAMETERS <i>(Contact Factory: Parameters are Application Specific)</i>		
MAX TEMP. (Inert Environment)	°F/°C	5400/3000
MAX. WORKING TEMP. ²	°F/°C	1800/1000
MAX. PRESSURE (valves) ²	psi/bar	4500/310
MAX. PUMP SPEED(without cooling flush)	ft/min (m/s)	4800(24.4)
CHEMICAL RESISTANCE (except in strong oxidizers)	pH	0-14

¹Refer to Warranty Certificate for details.

² Maximum working temperature and maximum working pressure are not considered simultaneously and vary with each application.

Slade, Inc

181 Crawford Rd * Statesville, NC 28625

tel: 704-873-1366 * fax: 704-873-1399 * website: www.slade-inc.com

Sold through distributors

within exclusive territories.

The above data, collected from in-house testing, field testing, and field applications, is subject to change without notice and must be used for examination ONLY. Contact the factory for suggestions on each application. Each application must be independently tested for safety and suitability. Failure to independently test can result in property damage and/or personal injury. S:5.1.13

SLADE 3300CJ Valve and Pump Packing



For flush free pump service with virtually leak free performance, contact the factory for specific recommendations. Carbon jacketed graphite packing used as an anti-extrusion or bull ring in high pressure pumps and valves as well as an anti-abrasion bottom ring in slurry applications. Commonly used in steam & chemical applications.

Recommended for valve emission containment up to 1200°F/650°C.

Lifetime warranty for valves¹

HIGH PURITY EXPANDED GRAPHITE PACKING

MANUFACTURER OF YARNS		Slade, Inc.
BRAIDER		Slade, Inc.
TYPE NAME		Slade, Inc.
TYPE NUMBER		3300CJ
TYPICAL COMPOSITION		
MAIN COMPONENT		Graphite/Carbon
STATE OF MAIN COMPONENT		Vermiculate
DENSITY before compression	lb/ft ³ (g/cm ³)	65 (1.04)
GRAPHITE PURITY	% Weight	99
ASH	% Weight	0.74
INHIBITOR TYPE		Phosphate or Zinc available
CARBON FIBER	% Weight	<25
GRAPHITE	% Weight	<75
POLYTETRAFLUOROETHYLENE/GRAPHITE IMPREGNANT	% Weight	<8
TYPICAL STANDARDS		
CHLORIDE LEACHABLE	ppm	10
TOTAL CHLORIDE	ppm	50
FLUORINE LEACHABLE	ppm	10
TOTAL FLUORINE	ppm	50
TOTAL SULFUR	ppm	330
WORKING PARAMETERS		
<i>(Contact Factory: Parameters are Application Specific)</i>		
MAX. TEMP. (Inert Environment)	°F/°C	1200/650
MAX. WORKING TEMP. ²	°F/°C	1200/650
MAX. PRESSURE (valves) ²	psi/bar	5000/345
MAX. PUMP SPEED (without cooling flush)	ft/min (m/s)	4800(24.4)
CHEMICAL RESISTANCE (except in strong oxidizers)	pH	0-14

¹ Refer to Warranty Certificate for details.

² Maximum working temperature and maximum working pressure are not considered simultaneously and vary with applications.

Slade, Inc

181 Crawford Rd * Statesville, NC 28625

tel: 704-873-1366 * fax: 704-873-1399 * website: www.slade-inc.com

Sold through distributors

within exclusive territories.

The above data, collected from in-house testing, field testing, and field applications, is subject to change without notice and must be used for examination ONLY. Contact the factory for suggestions on each application. Each application must be independently tested for safety and suitability. Failure to independently test can result in property damage and/or personal injury. S:1.1.12

SLADE 3300CJK Abrasive Isolator Packing



For flush free pump service with virtually leak free performance, contact the factory for specific recommendations. Carbon jacketed graphite & Kevlar packing used as an anti-extrusion or bull ring in high pressure applications, also as an anti-abrasion bottom ring in slurry applications. Commonly used in steam & chemical applications.

Recommended up to 500°F/260°C.

HIGH PURITY EXPANDED GRAPHITE PACKING

MANUFACTURER OF YARNS		Slade, Inc.
BRAIDER		Slade, Inc.
TYPE NAME		Slade, Inc.
TYPE NUMBER		3300CJK
TYPICAL COMPOSITION		
MAIN COMPONENT		Graphite/Carbon
STATE OF MAIN COMPONENT		Vermiculate
DENSITY before compression	lb/ft ³ (g/cm ³)	65 (1.04)
GRAPHITE PURITY	% Weight	99
ASH	% Weight	0.74
INHIBITOR TYPE		Phosphate or Zinc available
CARBON FIBER	% Weight	<15
ARAMID FIBER	% Weight	<15
FLEXIBLE GRAPHITE	% Weight	<70
POLYTETRAFLUOROETHYLENE/GRAPHITE IMPREGNANT	% Weight	<8
TYPICAL STANDARDS		
CHLORIDE LEACHABLE	ppm	10
TOTAL CHLORIDE	ppm	50
FLUORINE LEACHABLE	ppm	10
TOTAL FLUORINE	ppm	50
TOTAL SULFUR	ppm	330
WORKING PARAMETERS		
<i>(Contact Factory: Parameters are Application Specific)</i>		
MAX. TEMP (Inert Environment)	°F/°C	500/260
MAX. WORKING TEMP. ¹	°F/°C	500/260
MAX. PRESSURE (valves-reciprocating) ¹	psi/bar	5000/345
MAX. PUMP SPEED (without cooling flush)	ft/min (m/s)	2500/12.7
CHEMICAL RESISTANCE (except in strong oxidizers)	pH	2-12

¹ Maximum working temperature and maximum working pressure are not considered simultaneously and vary with applications.

Slade, Inc

181 Crawford Rd * Statesville, NC 28625

tel: 704-873-1366 * fax: 704-873-1399 * website: www.slade-inc.com

Sold through distributors

within exclusive territories.

The above data, collected from in-house testing, field testing, and field applications, is subject to change without notice and must be used for examination ONLY. Contact the factory for suggestions on each application. Each application must be independently tested for safety and suitability. Failure to independently test can result in property damage and/or personal injury. S:1.1.12

SLADE 3300G Valve and Pump Packing



For flush free pump service with virtually leak free performance, contact the factory for specific recommendations. Used in high pressure heater drain pumps, condensate, boiler feed, recirculation, make-up water, cooling water, auxiliary boiler feed, vacuum, and other water related applications. Commonly used in steam & chemical applications.

Recommended for valve emission containment up to 1800°F/1000°C.

Lifetime warranty for valves¹

HIGH PURITY EXPANDED GRAPHITE PACKING

MANUFACTURER OF YARNS		Slade, Inc.
BRAIDER		Slade, Inc.
TYPE NAME		Slade, Inc.
TYPE NUMBER		3300G
TYPICAL COMPOSITION		
MAIN COMPONENT		Graphite/Carbon
STATE OF MAIN COMPONENT		Vermiculate
DENSITY (braided: before die forming)	lb/ft ³ (g/cm ³)	65 (1.04)
GRAPHITE PURITY	% Weight	99
ASH	% Weight	0.74
INHIBITOR TYPE		Phosphate or Zinc available
CARBON FIBER per yarn	% Weight	<10
TYPICAL STANDARDS		
CHLORIDE LEACHABLE	ppm	10
TOTAL CHLORIDE	ppm	50
FLUORINE LEACHABLE	ppm	10
TOTAL FLUORINE	ppm	50
TOTAL SULFUR	ppm	560
WORKING PARAMETERS		
<i>(Contact Factory: Parameters are Application Specific)</i>		
MAX. TEMP. (Inert Environment)	°F/°C	5400/3000
MAX. WORKING TEMP. ²	°F/°C	1800/1000
MAX. PRESSURE (valves) ²	psi/bar	5000/345
MAX. PUMP SPEED (without cooling flush)	ft/min (m/s)	4800(24.4)
CHEMICAL RESISTANCE (except in strong oxidizers)	pH	0 - 14

¹ Refer to Warranty Certificate for details.

² Maximum working temperature and maximum working pressure are not considered simultaneously and vary with each application.

Slade, Inc

181 Crawford Rd * Statesville, NC 28625

tel: 704-873-1366 * fax: 704-873-1399 * website: www.slade-inc.com

Sold through distributors

within exclusive territories.

The above data, collected from in-house testing, field testing, and field applications, is subject to change without notice and must be used for examination ONLY. Contact the factory for suggestions on each application. Each application must be independently tested for safety and suitability. Failure to independently test can result in property damage and/or personal injury. S:1.1.12

SLADE 3300GLC Valve and Pump Packing



For flush free pump service with virtually leak free performance, contact the factory for specific recommendations. Same as our Slade 3300G packing but contains fewer leachable chlorides to allow suitable performance in nuclear applications . Commonly used in steam & chemical applications.

Recommended for valve emission containment up to 1800°F/1000°C.

Lifetime warranty for valves¹

HIGH PURITY EXPANDED GRAPHITE PACKING

MANUFACTURER OF YARNS		Slade, Inc.
BRAIDER		Slade, Inc.
TYPE NAME		Slade, Inc.
TYPE NUMBER		3300GLC
AVERAGE COMPOSITION		
MAIN COMPONENT		Graphite/Carbon
STATE OF MAIN COMPONENT		Vermiculite
DENSITY (braided: before die forming)	lb/ft ³ (g/cm ³)	65 (1.04)
GRAPHITE PURITY	% Weight	99
ASH	% Weight	0.74
INHIBITOR TYPE		Phosphate or Zinc available
CARBON FIBER per yarn	% Weight	<10
TYPICAL STANDARDS		
CHLORIDE LEACHABLE	ppm	10
TOTAL CHLORIDE	ppm	40
FLUORINE LEACHABLE	ppm	10
TOTAL FLUORINE	ppm	20
SULFUR LEACHABLE	ppm	40
TOTAL SULFUR	ppm	500
WORKING PARAMETERS		
<i>(Contact Factory: Parameters are Application Specific)</i>		
MAX. TEMP. (Inert Environment)	°F/°C	1800/1000
MAX. WORKING TEMP. ²	°F/°C	1800/1000
MAX. PRESSURE (valves) ²	psi/bar	5000/345
MAX. PUMP SPEED (without cooling flush)	ft/min (m/s)	4800(24.4)
CHEMICAL RESISTANCE (except in strong oxidizers)	pH	0-14

¹ Refer to Warranty Certificate for details.

² Maximum working temperature and maximum working pressure are not considered simultaneously and vary with applications.

Slade, Inc

181 Crawford Rd * Statesville, NC 28625

tel: 704-873-1366 * fax: 704-873-1399 * website: www.slade-inc.com

Sold through distributors

within exclusive territories.

The above data, collected from in-house testing, field testing, and field applications, is subject to change without notice and must be used for examination ONLY. Contact the factory for suggestions on each application. Each application must be independently tested for safety and suitability. Failure to independently test can result in property damage and/or personal injury. S: 1.1.12

SLADE 3300K Reciprocating Pump Packing



For flush free pump service with virtually leak free performance, contact the factory for specific recommendations. Kevlar packing commonly used in reciprocating, wastewater, steam, ammonia, and oil well sucker rod applications.

Recommended up to 500°F/260°C.

HIGH PURITY EXPANDED GRAPHITE PACKING

MANUFACTURER OF YARNS		Slade, Inc.
BRAIDER		Slade, Inc.
TYPE NAME		Slade, Inc.
TYPE NUMBER		3300K
TYPICAL COMPOSITION		
MAIN COMPONENT		Graphite/Carbon
STATE OF MAIN COMPONENT		Vermiculate
DENSITY (braided: before die forming)	lb/ft ³ (g/cm ³)	70 (1.12)
GRAPHITE PURITY	% Weight	99
ASH	% Weight	0.74
INHIBITOR TYPE		Phosphate or Zinc available
CARBON FIBER per yarn	% Weight	<10
KEVLAR FIBER per braid	% Weight	<25
GRAPHITE per yarn	% Weight	<80
TYPICAL STANDARDS		
CHLORIDE LEACHABLE	ppm	10
TOTAL CHLORIDE	ppm	50
FLUORINE LEACHABLE	ppm	10
TOTAL FLUORINE	ppm	50
TOTAL SULFUR	ppm	560
WORKING PARAMETERS		
<i>(Contact Factory: Parameters are Application Specific)</i>		
MAX. TEMP. (Inert Environment)	°F/°C	500/260
MAX. WORKING TEMP. ¹	°F/°C	500/260
MAX. PRESSURE ¹	psi/bar	5000/345
MAX. PUMP SPEED (without cooling flush)	ft/min (m/s)	2500/12.7
CHEMICAL RESISTANCE (except in strong oxidizers)	pH	2-12

¹Maximum working temperature and maximum working pressure are not considered simultaneously and vary with applications.

Slade, Inc

181 Crawford Rd * Statesville, NC 28625

tel: 704-873-1366 * fax: 704-873-1399 * website: www.slade-inc.com

Sold through distributors
within exclusive territories.

The above data, collected from in-house testing, field testing, and field applications, is subject to change without notice and must be used for examination ONLY. Contact the factory for suggestions on each application. Each application must be independently tested for safety and suitability. Failure to independently test can result in property damage and/or personal injury. S:1.1.12

SLADE 3300W Valve Packing

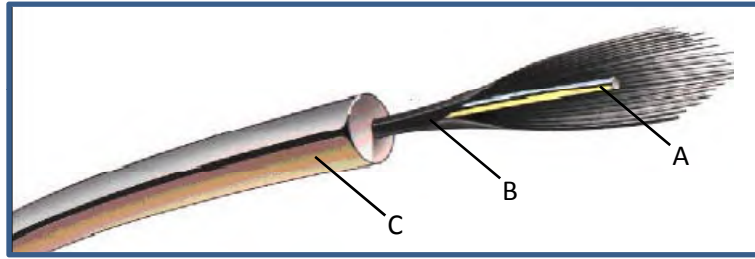

A: Inconel® wire core
 B: Carbon fiber shroud
 C: Graphite foil jacket

Product recommended for emissionless valve service in temperatures ranging from -328°F/-200°C up to 1800°F/1000°C; contact the factory for specific recommendations. High purity, low chloride, Inconel® wire reinforced valve packing commonly used in high temperature, high pressure, and emission control for valves and actuators. May be certified to meet the most stringent chemical contaminant requirements.

Lifetime Warranty for Valves ¹

HIGH PURITY EXPANDED GRAPHITE PACKING

MANUFACTURER OF YARNS		Slade, Inc.
BRAIDER		Slade, Inc.
TYPE NAME		Slade, Inc.
TYPE NUMBER		3300W
TYPICAL COMPOSITION		
MAIN COMPONENT		Graphite/Carbon
STATE OF MAIN COMPONENT		Vermiculate
DENSITY (braided: before die forming)	lb/ft ³ (g/cm ³)	70 (1.12)
GRAPHITE PURITY	% Weight	99
ASH	% Weight	0.74
INHIBITOR TYPE		Phosphate or Zinc available
CARBON FIBER per yarn	% Weight	<10
WIRE REINFORCEMENT per yarn	% Weight	<2
TYPICAL STANDARDS		
CHLORIDE LEACHABLE	ppm	10
TOTAL CHLORIDE	ppm	50
FLUORINE LEACHABLE	ppm	10
TOTAL FLUORINE	ppm	50
SULFUR LEACHABLE	ppm	24
TOTAL SULFUR	ppm	560
WORKING PARAMETERS		
<i>(Contact Factory: Parameters are Application Specific)</i>		
MAX. TEMP. (Steam) ²	°F/°C	1200/650
MAX. TEMP. (Inert Environment)	°F/°C	1800/1000
MAX. WORKING TEMP. ²	°F/°C	1800/1000
MAX. PRESSURE	psi/bar	5000/345
CHEMICAL RESISTANCE (except in strong oxidizers)	pH	0 - 14

¹ Refer to Warranty Certificate for details.

² Maximum working temperature and maximum working pressure are not considered simultaneously and vary with each application.

Slade, Inc

181 Crawford Rd * Statesville, NC 28625

tel: 704-873-1366 * fax: 704-873-1399 * website: www.slade-inc.com

Sold through distributors
 within exclusive territories.

The above data, collected from in-house testing, field testing, and field applications, is subject to change without notice and must be used for examination ONLY. Contact the factory for suggestions on each application. Each application must be independently tested for safety and suitability. Failure to independently test can result in property damage and/or personal injury. S:1.1.12

SLADE 3300i Valve Packing

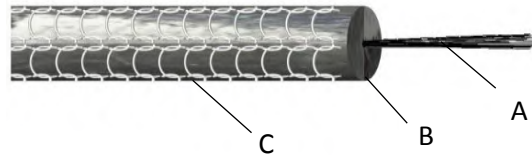

A: Carbon fiber shroud
B: Graphite foil jacket
C: Inconel® wire knitted jacket

Product recommended for emissionless valve service in temperatures ranging from -328°F/-200°C up to 1800°F/1000°C; contact the factory for specific recommendations. High purity, low chloride, Inconel® wire reinforced valve packing commonly used in high temperature, high pressure, and emission control for valves and actuators. May be certified to meet the most stringent chemical contaminant requirements.

Lifetime Warranty for Valves ¹

HIGH PURITY EXPANDED GRAPHITE PACKING

MANUFACTURER OF YARNS		Slade, Inc.
BRAIDER		Slade, Inc.
TYPE NAME		Slade, Inc.
TYPE NUMBER		3300i
TYPICAL COMPOSITION		
MAIN COMPONENT		Graphite/Carbon/Inconel wire®
STATE OF MAIN COMPONENT		Expanded
DENSITY (braided: before die forming)	lb/ft ³ (g/cm ³)	87.68 (1.40)
GRAPHITE PURITY	% Weight	99
ASH	% Weight	0.74
INHIBITOR TYPE		Passive (standard)
INHIBITOR TYPE		Zinc (available upon request)
TOTAL INCONEL	% Weight	15
TOTAL NICKEL	% Weight	>70
TYPICAL STANDARDS		
CHLORIDE LEACHABLE	ppm	10
TOTAL CHLORIDE	ppm	50
FLUORINE LEACHABLE	ppm	10
TOTAL FLUORINE	ppm	50
SULFUR LEACHABLE	ppm	24
TOTAL SULFUR	ppm	560
WORKING PARAMETERS		
<i>(Contact Factory: Parameters are Application Specific)</i>		
MAX. TEMP. (Steam) ²	°F/°C	1200/650
MAX. TEMP. (Inert Environment)	°F/°C	1800/1000
MAX. WORKING TEMP. ²	°F/°C	1800/1000
MAX. PRESSURE	psi/bar	6000/414
CHEMICAL RESISTANCE (except in strong oxidizers)	pH	0 - 14

¹ Refer to Warranty Certificate for details.

² Maximum working temperature and maximum working pressure are not considered simultaneously and vary with each application.

Slade, Inc

181 Crawford Rd * Statesville, NC 28625

tel: 704-873-1366 * fax: 704-873-1399 * website: www.slade-inc.com

Sold through distributors
within exclusive territories.

The above data, collected from in-house testing, field testing, and field applications, is subject to change without notice and must be used for examination ONLY. Contact the factory for suggestions on each application. Each application must be independently tested for safety and suitability. Failure to independently test can result in property damage and/or personal injury. S:5.1.13

SLADE DSS Pump Spacer Bushing

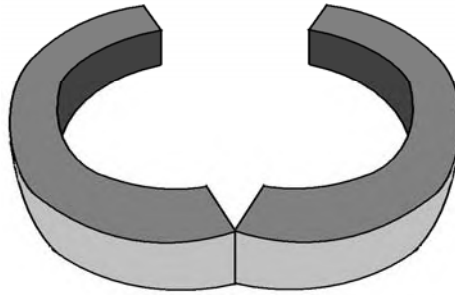

A densely dieformed braided graphite and stainless steel pump spacer bushing used to minimize the amount of packing required in pump applications. Use in applications that previously required a solid spacer bushing or an excessive amount of packing. Available in various sizes and able to withstand the same conditions as other Slade 3300 products.

HIGH PURITY EXPANDED GRAPHITE PACKING

MANUFACTURER OF YARNS		Slade, Inc.
BRAIDER		Slade, Inc.
TYPE NAME		Slade, Inc.
TYPE NUMBER		DSS
TYPICAL COMPOSITION		
MAIN COMPONENT		Graphite/SS Foils
STATE OF MAIN COMPONENT		Vermiculate
DENSITY DIE FORMED	lb/ft ³ (g/cm ³)	124 (1.98)
GRAPHITE PURITY	% Weight	99
ASH	% Weight	0.74
304 STAINLESS STEEL FOIL per yarn	% Weight	<25
TYPICAL STANDARDS		
CHLORIDE LEACHABLE	ppm	10
TOTAL CHLORIDE	ppm	50
FLUORINE LEACHABLE	ppm	10
TOTAL FLUORINE	ppm	50
TOTAL SULFUR	ppm	560
WORKING PARAMETERS (Contact Factory: Parameters are Application Specific)		
MAX. TEMP. (Inert Environment)	°F/°C	1400/760
MAX. WORKING TEMP.	°F/°C	1400/760
MAX. PRESSURE (valves) ¹	psi/bar	4500/310
MAX. PUMP SPEED (without cooling flush)	ft/min (m/s)	contact factory
CHEMICAL RESISTANCE (except in strong oxidizers)	pH	0-14

¹ Maximum temperature and maximum pressure are not to be used simultaneously and vary with each application.

Slade, Inc

181 Crawford Rd * Statesville, NC 28625

tel: 704-873-1366 * fax: 704-873-1399 * website: www.slade-inc.com

Sold through distributors
within exclusive territories.

The above data, collected from in-house testing, field testing, and field applications, is subject to change without notice and must be used for examination ONLY. Contact the factory for suggestions on each application. Each application must be independently tested for safety and suitability. Failure to independently test can result in property damage and/or personal injury. S:1.1.12

SLADE EnviroFoil Spacer Bushing

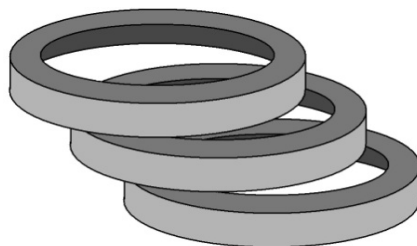

A densely dieformed braided graphite and stainless steel spacer bushing used to minimize the amount of packing required in valve applications. Use in applications that previously required a solid spacer bushing or an excessive amount of packing. Available in various sizes and able to withstand the same conditions as other Slade 3300 products.

Recommended for valve emission containment up to 1400°F/1000°C.

Lifetime warranty for valves¹

HIGH PURITY EXPANDED GRAPHITE PACKING

MANUFACTURER OF YARNS		Slade, Inc.
BRAIDER		Slade, Inc.
TYPE NAME		Slade, Inc.
TYPE NUMBER		VDG
TYPICAL COMPOSITION		
MAIN COMPONENT		Graphite/SS Foils
STATE OF MAIN COMPONENT		Vermiculate
DENSITY DIE FORMED	lb/ft ³ (g/cm ³)	124 (1.98)
GRAPHITE PURITY	% Weight	99
ASH	% Weight	0.74
304 STAINLESS STEEL FOIL per yarn	% Weight	<25
TYPICAL STANDARDS		
CHLORIDE LEACHABLE	ppm	10
TOTAL CHLORIDE	ppm	50
FLUORINE LEACHABLE	ppm	10
TOTAL FLUORINE	ppm	50
TOTAL SULFUR	ppm	560
WORKING PARAMETERS		
<i>(Contact Factory: Parameters are Application Specific)</i>		
MAX. TEMP. (Inert Environment)	°F/°C	1400/760
MAX. WORKING TEMP. ²	°F/°C	1400/760
MAX. PRESSURE (valves) ²	psi/bar	4500/310
CHEMICAL RESISTANCE (except in strong oxidizers)	pH	0-14

¹ Refer to Warranty Certificate for details.

² Maximum working temperature and maximum working pressure are not considered simultaneously and vary with applications.

Slade, Inc

181 Crawford Rd * Statesville, NC 28625

tel: 704-873-1366 * fax: 704-873-1399 * website: www.slade-inc.com

Sold through distributors

within exclusive territories.

The above data, collected from in-house testing, field testing, and field applications, is subject to change without notice and must be used for examination ONLY. Contact the factory for suggestions on each application. Each application must be independently tested for safety and suitability. Failure to independently test can result in property damage and/or personal injury. S:1.1.12

SLADE VDG Spacer Bushing

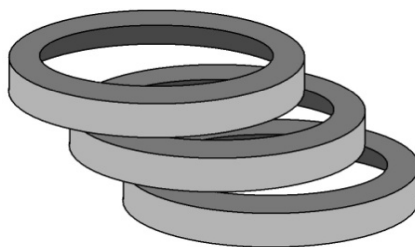

A densely dieformed, braided, vapor deposited graphite and stainless steel spacer bushing used to minimize the amount of packing required in pump & valve applications. Use in applications that previously required a solid spacer bushing or an excessive amount of packing. Available in various sizes and able to withstand the same conditions as other Slade 3300 products.

Recommended for valve emission containment up to 1400°F/1000°C.

Lifetime warranty for valves¹

HIGH PURITY EXPANDED GRAPHITE PACKING

MANUFACTURER OF YARNS		Slade, Inc.
BRAIDER		Slade, Inc.
TYPE NAME		Slade, Inc.
TYPE NUMBER		VDG
TYPICAL COMPOSITION		
MAIN COMPONENT		Graphite/SS Foils
STATE OF MAIN COMPONENT		Vapor Deposited
DENSITY DIE FORMED	lb/ft ³ (g/cm ³)	124 (1.98)
GRAPHITE PURITY	% Weight	99
ASH	% Weight	0.74
304 STAINLESS STEEL FOIL	% Weight	<25
TYPICAL STANDARDS		
CHLORIDE LEACHABLE	ppm	10
TOTAL CHLORIDE	ppm	50
FLUORINE LEACHABLE	ppm	10
TOTAL FLUORINE	ppm	50
TOTAL SULFUR	ppm	560
WORKING PARAMETERS		
<i>(Contact Factory: Parameters are Application Specific)</i>		
MAX. TEMP. (Inert Environment)	°F/°C	1400/760
MAX. WORKING TEMP. ²	°F/°C	1400/760
MAX. PRESSURE (valves) ²	psi/bar	4500/310
MAX. PUMP SPEED (without cooling flush)	ft/min (m/s)	contact factory
CHEMICAL RESISTANCE (except in strong oxidizers)	pH	0-14

¹ Refer to Warranty Certificate for details.

² Maximum working temperature and maximum working pressure are not considered simultaneously and vary with applications.

Slade, Inc

181 Crawford Rd * Statesville, NC 28625

tel: 704-873-1366 * fax: 704-873-1399 * website: www.slade-inc.com

Sold through distributors

within exclusive territories.

The above data, collected from in-house testing, field testing, and field applications, is subject to change without notice and must be used for examination ONLY. Contact the factory for suggestions on each application. Each application must be independently tested for safety and suitability. Failure to independently test can result in property damage and/or personal injury. S:1.1.12

SLADE Soot Blower Packing

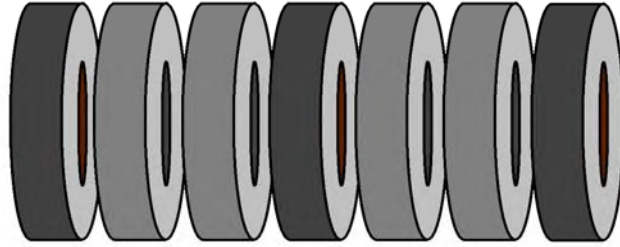

Slade's patented 3300G packing staggered with graphite impregnated alloy rings to allow an excellent seal without compromising strength. Each ring set is specifically engineered for blower application and style. Benefits include increased packing life, quieter operation, and less amperage draw.

HIGH PURITY EXPANDED GRAPHITE PACKING

MANUFACTURER OF YARNS		Slade, Inc.
BRAIDER		Slade, Inc.
TYPE NAME		Slade, Inc.
TYPE NUMBER		Soot Blower Packing
TYPICAL COMPOSITION		
MAIN COMPONENT		Graphite/Alloy
STATE OF MAIN COMPONENT		Vermiculate
DENSITY DIE FORMED (alloy ring)	lb/ft ³ (g/cm ³)	320 (5.13)
GRAPHITE PURITY	% Weight	99
ASH	% Weight	0.74
INHIBITOR TYPE		Phosphate or Zinc available
TYPICAL STANDARDS		
CHLORIDE LEACHABLE	ppm	10
TOTAL CHLORIDE	ppm	50
FLUORINE LEACHABLE	ppm	10
TOTAL FLUORINE	ppm	50
TOTAL SULFUR	ppm	560
WORKING PARAMETERS		
<i>(Contact Factory: Parameters are Application Specific)</i>		
MAX. WORKING TEMP. ¹	°F/°C	1800/1000
CHEMICAL RESISTANCE (avoid strong oxidizers and acids)	pH	Contact Factory

¹ Maximum working temperature and maximum working pressure are not considered simultaneously and vary with applications.

Slade, Inc
 181 Crawford Rd * Statesville, NC 28625
 tel: 704-873-1366 * fax: 704-873-1399 * website: www.slade-inc.com

Sold through distributors
 within exclusive territories.

The above data, collected from in-house testing, field testing, and field applications, is subject to change without notice and must be used for examination ONLY. Contact the factory for suggestions on each application. Each application must be independently tested for safety and suitability. Failure to independently test can result in property damage and/or personal injury. S:1.1.12

SLADE Stuffit Injectable Packing



An injectable carbon fiber reinforced graphite flake compound used for hot tapping valves in continuous operation and various other applications. Commonly used in valves, expansion joints, and heavily worn pumps. Recommended for valve emission containment up to 840°F/450°C. Contact factory.

HIGH PURITY EXPANDED GRAPHITE PACKING

MANUFACTURER OF YARNS		Slade, Inc.
BRAIDER		Slade, Inc.
TYPE NAME		Slade, Inc.
TYPE NUMBER		Stuffit
TYPICAL COMPOSITION		
MAIN COMPONENT		Graphite/Carbon
STATE OF MAIN COMPONENT		Expanded
DENSITY (bulk: pre-tapping) ¹	lb/ft ³ (g/cm ³)	27.5 (0.44)
GRAPHITE PURITY	% Weight	99
ASH	% Weight	<0.74
EXPANDED GRAPHITE FOIL	% Weight	<65
CASTOR OIL	% Weight	<35
CARBON FIBER	% Weight	<5
VEGETABLE OIL	% Weight	<5
WORKING PARAMETERS		
<i>(Contact Factory: Parameters are Application Specific)</i>		
MAX. TEMP. (Inert Environment)	°F/°C	840/450
MAX. WORKING TEMP. ²	°F/°C	840/450
CHEMICAL RESISTANCE (except in strong oxidizers)	pH	0-14

¹ Mix well before use.

² Maximum working temperature and maximum working pressure are not considered simultaneously and vary with applications. The temperature limit refers to the solids in the injectable packing.

Slade, Inc
 181 Crawford Rd * Statesville, NC 28625
 tel: 704-873-1366 * fax: 704-873-1399 * website: www.slade-inc.com

Sold through distributors
 within exclusive territories.

The above data, collected from in-house testing, field testing, and field applications, is subject to change without notice and must be used for examination ONLY. Contact the factory for suggestions on each application. Each application must be independently tested for safety and suitability. Failure to independently test can result in property damage and/or personal injury. S:1.1.12

SLADE Pyro-Tex Joint Sealant Carbon Fiber Reinforced

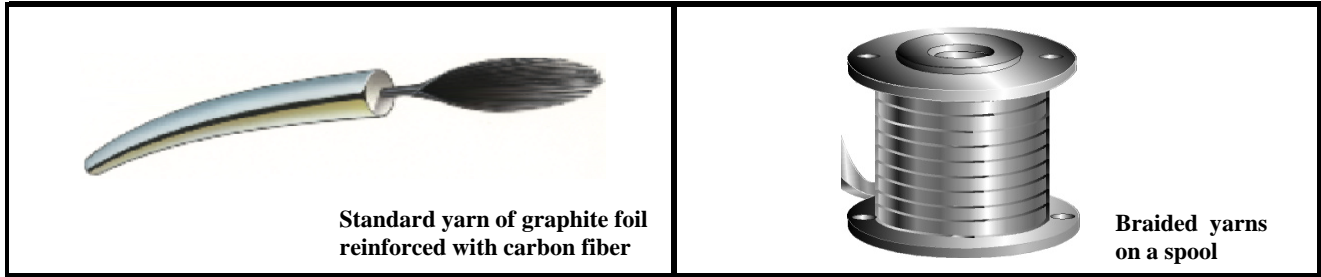

CARBON FIBER reinforced self-forming gasket

MANUFACTURER OF YARNS		Slade Inc.
MANUFACTURED ACCORDING TO		Slade USA & International Patents
BRAIDER/WEAVER OF FINISHED PRODUCT		Slade Inc.
TYPE		Carbon fiber reinforced
STYLE/NAME		PyroTex Joint Sealant Standard
STANDARD PACKAGING ON SPOOLS		25' & 50' lengths
STANDARD SHAPES		Rectangular & Semi Round
NON-STANDARD SHAPES		Delta, Round & as Specified by Customer
<u>TYPICAL COMPOSITION</u>		
MAIN COMPONENT		Graphite & Carbon Fiber
STATE OF MAIN COMPONENTS		Braided, woven & calendered to shape
DENSITY (braided: pre-compression)	lb/ft ³ (g/cm ³)	75 (1.2)
GRAPHITE PURITY	% Weight	99
ASH	% Weight	0.74
CARBON FIBER per yarn	% Weight	<10
<u>TYPICAL STANDARDS</u>		
CHLORIDE LEACHABLE	ppm	10
TOTAL CHLORIDE	ppm	50
FLUORINE LEACHABLE	ppm	10
TOTAL FLUORINE	ppm	50
TOTAL SULFUR	ppm	560
<u>WORKING PARAMETERS</u>		
MAX TEMP (Inert Environment)	°F/°C	1400/760
MAX WORKING TEMP (EXHAUST GASES) ¹	°F/°C	1400/760
MAXIMUM PRESSURE RESISTANCE	psi/bar	low pressure services only (Contact factory)
CHEMICAL RESISTANCE (except in strong oxidizers)	pH	0 - 14
M: Maintenance Factor ²		low pressure services only
Y: Minimum Seating Stress ²	(q=1.0 ml/min) psi/bar	3190/220

¹ Maximum temperature and maximum pressure are not to be used simultaneously and vary with each application.

² Based upon bolted flange joint strength analysis. Not intended to give gasket stress assembly limitations.

Slade Inc.
181 Crawford Rd * Statesville, NC 28625
tel: 704-873-1366 * fax: 704-873-1399 * website: www. Slade-inc.com

Manufacturer of 80" X 80" Gasket
Sheet, Pump Packings & Emission
Control Valve Packings

² Based upon bolted flange joint strength analysis. Not intended to give gasket stress assembly limitations.

The above data collected from in-house testing, field testing, and field applications, is subject to change without notice and must be used for examination ONLY. **Contact the factory for suggestions on each application.** Each application must be independently tested for safety and suitability.

Failure to independently test can result in property damage and/or personal injury.

S:1.1.12

SLADE Pyro-Tex Joint Sealant Style HP:

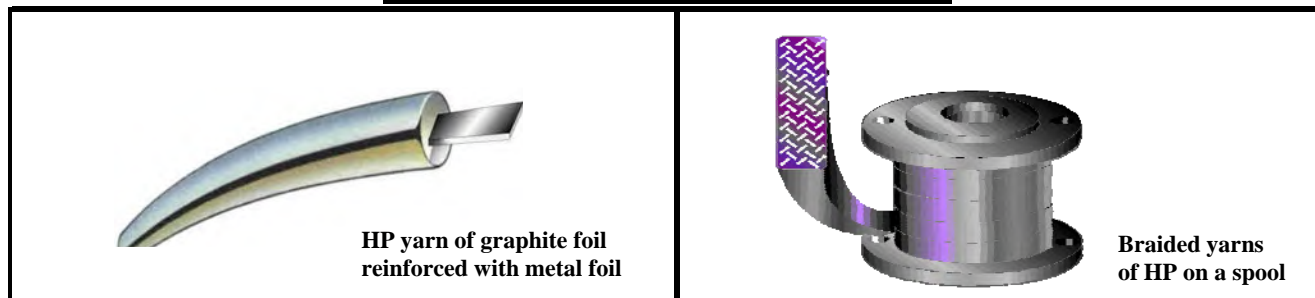

HIGH PRESSURE (HP) 304 stainless steel foil reinforced self-forming gasket

MANUFACTURER OF YARNS		Slade Inc.
MANUFACTURED ACCORDING TO		Slade USA & International Patents
BRAIDER/WEAVER OF FINISHED PRODUCT		Slade Inc.
TYPE		SS reinforced joint sealant
STYLE/NAME		HP PyroTex
STANDARD PACKAGING ON SPOOLS		25' & 50' lengths
STANDARD SHAPES		Rectangular & Semi Round
NON-STANDARD SHAPES		Delta, Round & as Specified by Customer
<u>TYPICAL COMPOSITION</u>		
MAIN COMPONENT		Graphite & SS Foils
STATE OF MAIN COMPONENTS		Braided, woven & calendered to shape
DENSITY (braided: pre-compression)	lb/ft ³ (g/cm ³)	84 (1.35)
GRAPHITE PURITY	% Weight	99
ASH	% Weight	0.74
304 STAINLESS STEEL FOIL per yarn	% Weight	20
<u>TYPICAL STANDARDS</u>		
CHLORIDE LEACHABLE	ppm	10
TOTAL CHLORIDE	ppm	50
FLUORINE LEACHABLE	ppm	10
TOTAL FLUORINE	ppm	50
TOTAL SULFUR	ppm	560
<u>WORKING PARAMETERS</u>		
MAX TEMP (Inert Environment)	°F/°C	1400/760
MAX WORKING TEMP (EXHAUST GASES)	°F/°C	1400/760
MAXIMUM PRESSURE RESISTANCE ¹	psi/bar	4500/310
CHEMICAL RESISTANCE (Contact Factory)	pH	4-10
M: Maintenance Factor ²	(q=1.0 ml/min)	4.6
Y: Minimum Seating Stress ²	(q=1.0 ml/min) psi/bar	1960/135

¹ Maximum temperature and maximum pressure are not to be used simultaneously and vary with each application.

² Based upon bolted flange joint strength analysis. Not intended to give gasket stress assembly limitations.

Slade Inc.

181 Crawford Rd * Statesville, NC 28625

tel: 704-873-1366 * fax: 704-873-1399 * website: www. Slade-inc.com

Manufacturer of 80" X 80" Gasket
Sheet, Pump Packings & Emission
Control Valve Packings

The above data, collected from in-house testing, field testing, and field applications, is subject to change without notice and must be used for examination ONLY. **Contact the factory for suggestions on each application.** Each application must be independently tested for safety and suitability. Failure to independently test can result in property damage and/or personal injury.

S:1.1.12

SLADE Pyro-Tex™ GASKET SHEET

Stainless Steel Reinforced Woven GRAPHITE Sheet



Individual Strand

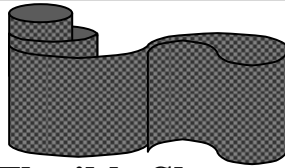

Flexible Sheet

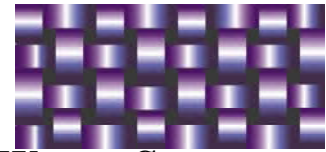

Woven Structure

Patent Protection: US and Foreign Patents

Construction of Gasket: Woven & Compressed sheet gasketing

Construction of Weaving Yarns: Individual flat 304 SS foil strips (not wire), encapsulated in graphite, form unique metal/graphite yarns suitable for weaving 80"x80" high strength sheets.

TYPICAL PHYSICAL PROPERTIES

PROPERTY	ENGLISH	METRIC
Density	75 lb/ft ³	1.20 g/cm ³
Leachable chlorides	10 PPM	10 PPM
Sulfur ¹	560 PPM	560 PPM
Ash content	0.74%	0.74%
Compressibility (T _{room})	34%	34%
Recovery (T _{room})	6%	6%
Tensile along length	2200 psi	15.17 MPa
Compressive strength	35,000 psi	241.32 MPa
Temperature range		
Inert media	-400 ⁰ F – 1400 ⁰ F	-240 ⁰ C – 760 ⁰ C
Oxidizing media	-400 ⁰ F– 975 ⁰ F	-240 ⁰ C – 524 ⁰ C
Strong oxidizers	Consult Factory	Consult Factory
Maximum fluid pressure ²	4500 psi	31.03 MPa
M Factor ³	4	4
Y Stress ³	3190 psi	22 MPa

¹ Use Pyro-Tex Gasket Sheet GLC-2 for high purity applications in nuclear power generation.

² Maximum temperature and maximum pressure not to be used simultaneously and vary with each application.

³ Based upon bolted flange joint strength analysis, not leakage. Not intended to give gasket stress assembly limitations.

THE GASKET in a CLASS of ITS OWN

According to the BHR Group report, *Development of Gaskets Made from Expanded Graphite* by M. Gawlinski and J. Blachura (given at the Sealing for Pollution Prevention and Control 18th International Conference on Fluid Sealing in Belgium), the Pyro-Tex Woven Gasket (1) maintains a superior tightness over other graphite gaskets during temperature cycling due to its adherence to the sealing surface; (2) operates with high tightness due to the low tangential resistance at compression.

Thus, a larger than typical compression set, due to the presence of graphite surface nodules, is not a deterrent to its sealing capabilities. The graphite surface nodules, as illustrated below, are designed to flow into flange surface imperfections. The Pyro-Tex Gasket Sheet is in a different classification when standard commercial tests are performed. The disparity in free thickness due to the surface is much greater than the thickness at which a seal is achieved.

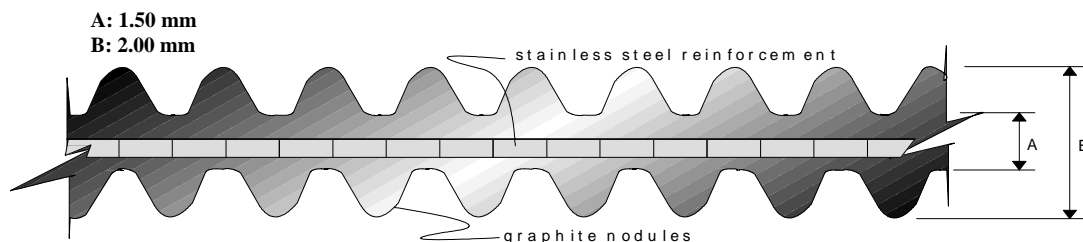

The above data, collected from in-house testing, field testing, and field applications, is subject to change without notice and must be used for examination ONLY. Contact the factory for suggestions on each application. Each application must be independently tested for safety and suitability. Failure to independently test can result in property damage and/or personal injury. S:1.1.12

SLADE Tang Gasket Sheet

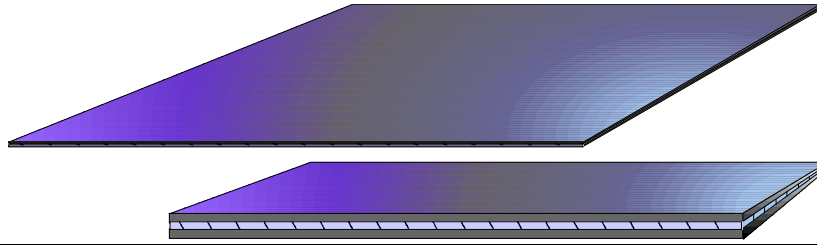

Slade Tang Sheet

Style 24T Industrial Grade

Sizes: 39.4" x 39.4" / 39.4" x 60" / 60" x 60"

Optional: steel insert thickness .003" - .180"

Construction of sheet: 0.004" thick stainless steel sheet is mechanically bonded between two graphite foil sheets to create a high temperature gasket sheet for chemical, power, nuclear, and other fluid sealing applications.

STAINLESS STEEL REINFORCED LAMINATED SHEET

MAIN COMPONENT		Graphite/Stainless Steel
TYPE NAME		Slade, Inc. Tang
<u>TYPICAL COMPOSITION</u>		
CARBON CONTENT SPECIFICATION	%	99.0
DENSITY	lb/ft ³ (g/cm ³)	70.0 (1.1)
ASH	% Weight	<1.0
AREA WEIGHT VARIATION	%	3.5
<u>TYPICAL STANDARDS</u>		
TOTAL CHLORINE	ppm	25
TOTAL SULFUR	ppm	550
LOSS OF WEIGHT (24hr, 500°C)	%	0.5
COMPRESSIBILITY	%	45-52
RECOVERY	%	10-15
CREEP RELAXATION	%	<5.0
STABILITY UNDER STRESS	N/mm	48
SEALABILITY	mi/hr	0.5
ASTM "m" FACTOR		2.5
ASTM "y" FACTOR	psi (bar)	2000 (138)
GAS PERMEABILITY		<1.0
PVRC CONSTANTS	Gb / a / Gs	1400 / 0.324 / 0.01
MAXIMUM WIDTH	in (m)	63 (1.5)
INSERT THICKNESS	in	0.004
<u>WORKING PARAMETERS</u>		
<i>(Contact Factory: Parameters are Application Specific)</i>		
MAXIMUM OPERATING TEMP (air)	°F/°C	1022/550
MAXIMUM OPERATING TEMP (steam)	°F/°C	1382/750
MAXIMUM OPERATING TEMP (neutral atmosphere)	°F/°C	5432/3000
T _p MAX @ 15000psi		2287
MAXIMUM PRESSURE ¹	psi (bar)	3234 (220)

¹ Maximum temperature and maximum pressure are not to be used simultaneously and vary with each application.

Slade, Inc

181 Crawford Rd * Statesville, NC 28625

tel: 704-873-1366 * fax: 704-873-1399 * website: www.slade-inc.com

Sold through distributors

within exclusive territories.

The above data is subject to change without notice and must be used for examination ONLY. Contact the factory for suggestions on each application. Each application must be independently tested for safety and suitability. Failure to independently test can result in property damage and/or personal injury.

S:1.1.12

WAY-2-Seal

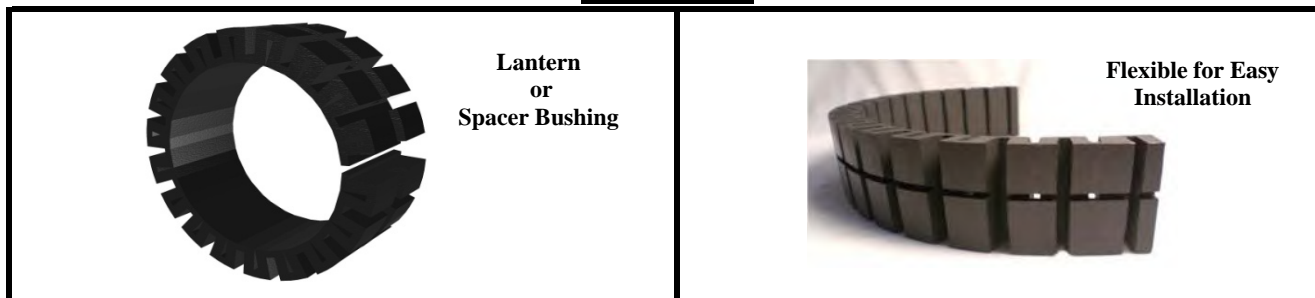

Way-2-Seal Lantern or Spacer Bushing

MANUFACTURER OF Way-2-Seal		Slade Inc.
MANUFACTURED ACCORDING TO		Slade USA & International Patents
STYLE/NAME		Way-2-Seal
STANDARD PACKAGING		Lengths
STANDARD SHAPES		Rectangular
<u>AVERAGE COMPOSITION</u>		
MAIN COMPONENT		Carbon, Graphite, PTFE
STATE OF MAIN COMPONENTS		Solid
SPECIFIC GRAVITY		2.09
COMPRESSIVE STRENGTH (10% deformation)	psi/bar	1700/117
COMPRESSIVE DESTRUCTIVE STRENGTH	psi/bar	5000/345
COEFFICIENT OF FRICTION (Dry to Steel: Dynamic)		0.11
GRAPHITE CONTENT	% Wt	<10
POLYTETRAFLUOROETHYLENE CONTENT	% Wt	<80
CARBON CONTENT	% Wt	<30

<u>WORKING PARAMETERS</u>		
MAX CONTINUOUS SERVICE TEMP	°F/°C	500/260
EMBRITTEMENT TEMP	°F/°C	-400/-240
CRYSTALLINE MELT TEMP	°F/°C	621/327
THERMAL CONDUCTIVITY	BTU-in(hr/ft ² °F)	4.5
CHEMICAL RESISTANCE	pH	0-14
<i>CONTACT FACTORY for SUGGESTIONS on PARAMETERS for EACH APPLICATION</i>		

Slade Inc.
181 Crawford Rd * Statesville, NC 28625
tel: 704-873-1366 * fax: 704-873-1399 * website: www. Slade-inc.com

Manufacturer of 80" X 80" Gasket
Sheet, Pump Packings & Emission
Control Valve Packings

The above data, collected from in-house testing, field testing, and field applications, is subject to change without notice and must be used for examination ONLY. **Contact the factory for suggestions on each application.** Each application must be independently tested for safety and suitability. Failure to independently test can result in property damage and/or personal injury.

S:1.1.12

PACKING COMPRESSOR KIT

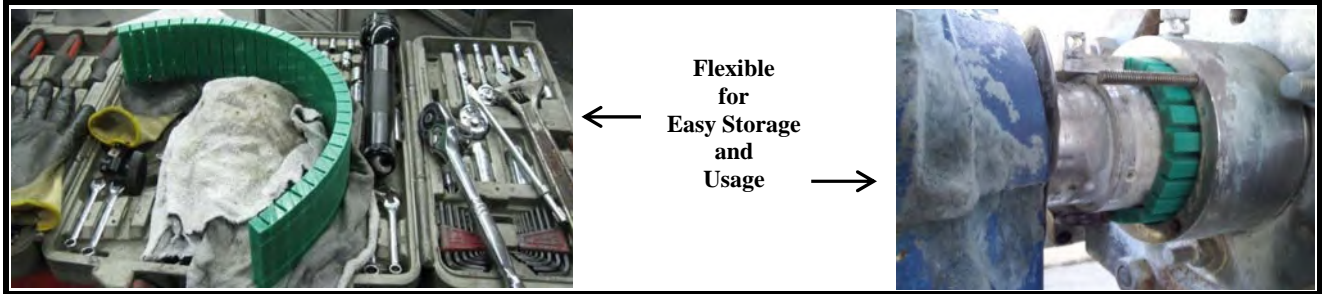

Packing Compressor Kit (PCK)

MANUFACTURER OF PCK		Slade Inc.
MANUFACTURED ACCORDING TO		Slade USA & International Patents
STYLE/NAME		PCK
STANDARD PACKAGING		Lengths
STANDARD SHAPES		Rectangular
STANDARD SIZES		1/4" to 1"
<u>AVERAGE COMPOSITION</u>		
MAIN COMPONENT		Polyethylene
STATE OF MAIN COMPONENTS		Solid
DENSITY	g/cm ³	0.93
COMPRESSIVE DESTRUCTIVE STRENGTH	psi/bar	< 5000/345
COEFFICIENT OF FRICTION (Dry to Steel: Static)		.15-.20
POLYETHYLENE CONTENT	% Wt	<100
<u>WORKING PARAMETERS</u>		
RECOMMENDED SERVICE TEMP	°F/°C	ambient
MAX CONTINUOUS SERVICE TEMP	°F/°C	180/82
CRYSTALLINE MELT TEMP	°F/°C	275/135
REMOVE the PCK before START-UP! <u>NOT</u> to be used in the stuffing box as a spacer.		

Slade Inc.
 181 Crawford Rd * Statesville, NC 28625
 tel: 704-873-1366 * fax: 704-873-1399 * website: www. Slade-inc.com

Manufacturer of 80" X 80" Gasket
 Sheet, Pump Packings & Emission
 Control Valve Packings

The above data, collected from in-house testing, field testing, and field applications, is subject to change without notice and must be used for examination ONLY. **Contact the factory for suggestions on each application.** Each application must be independently tested for safety and suitability. Failure to independently test can result in property damage and/or personal injury.

S:1.1.12

SLADE

PATENTED SEALING PRODUCTS

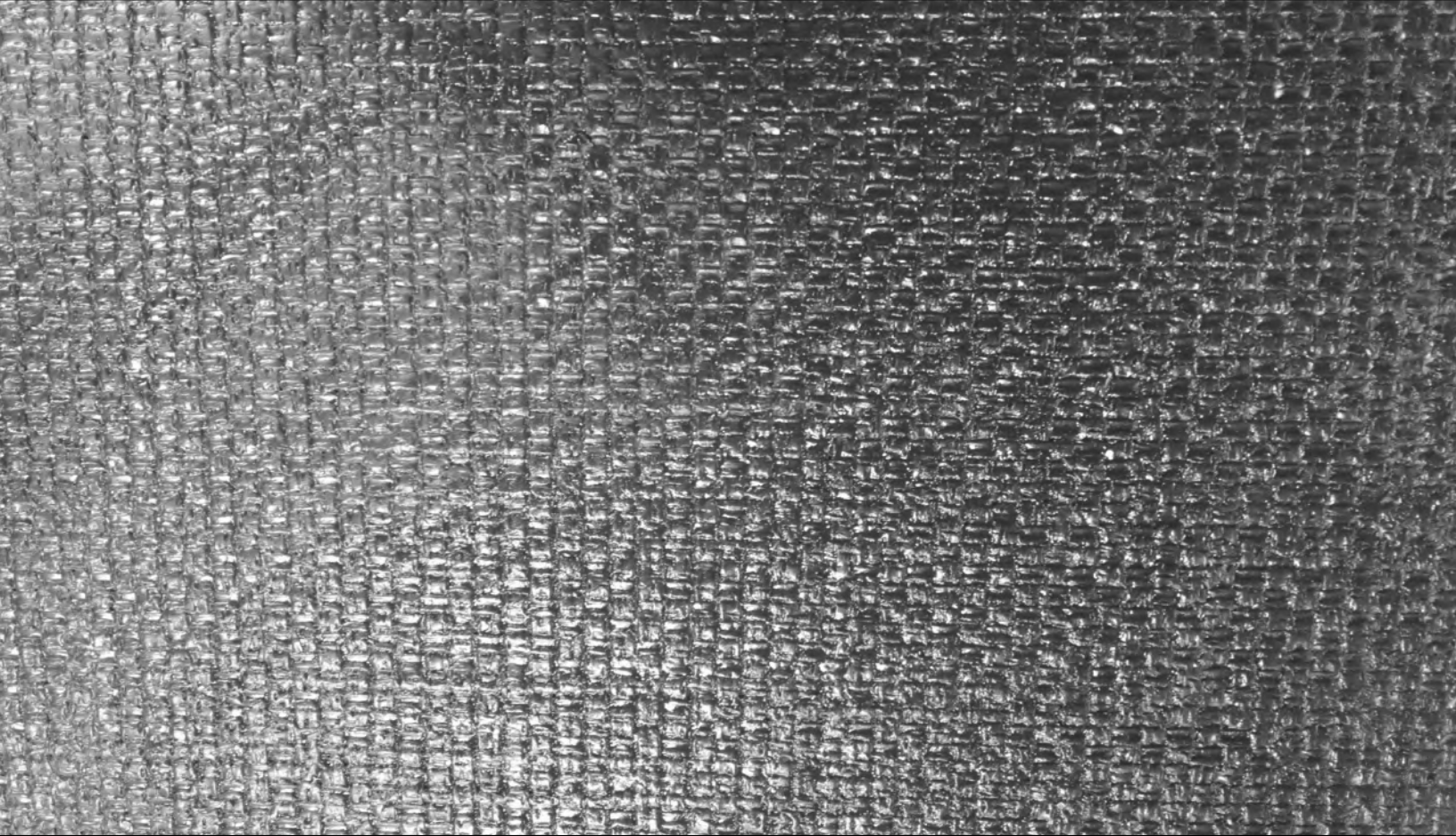

SLADE

For Benelux:



WEGMAN

Utrecht, The Netherlands

T: +31 (0)30 263 4000

F: +31 (0)30 263 4005

wegman@wegman.nl

181 Crawford Rd. Statesville, NC 28625

Website: www.slade-inc.com

Email: sales@slade-inc.com

Phone: 704-873-1366

Fax: 704-873-1399