



## WKM 320F

Flanged floating ball valves

# Contents

## **WKM 320F Flanged Floating Ball Valves**

Features and benefits .....	3
Exploded views and specifications .....	5
Materials list .....	6
Actuator trim codes .....	6
How to order .....	7
Trim codes .....	7
Dimensional data—1/2-in full port through 8-in × 6-in reduced port .....	8
Dimensions .....	9
Torque estimation and MAST .....	11
Weights .....	11

# Features and Benefits

The handle can be correctly installed only in alignment with the ball port. The valve is open when the handle is aligned with piping and is closed when the handle is perpendicular to piping.

## ASME Classes 150 through 600

½-in full port through 8-in reduced port

NACE MR0175/ISO 15156

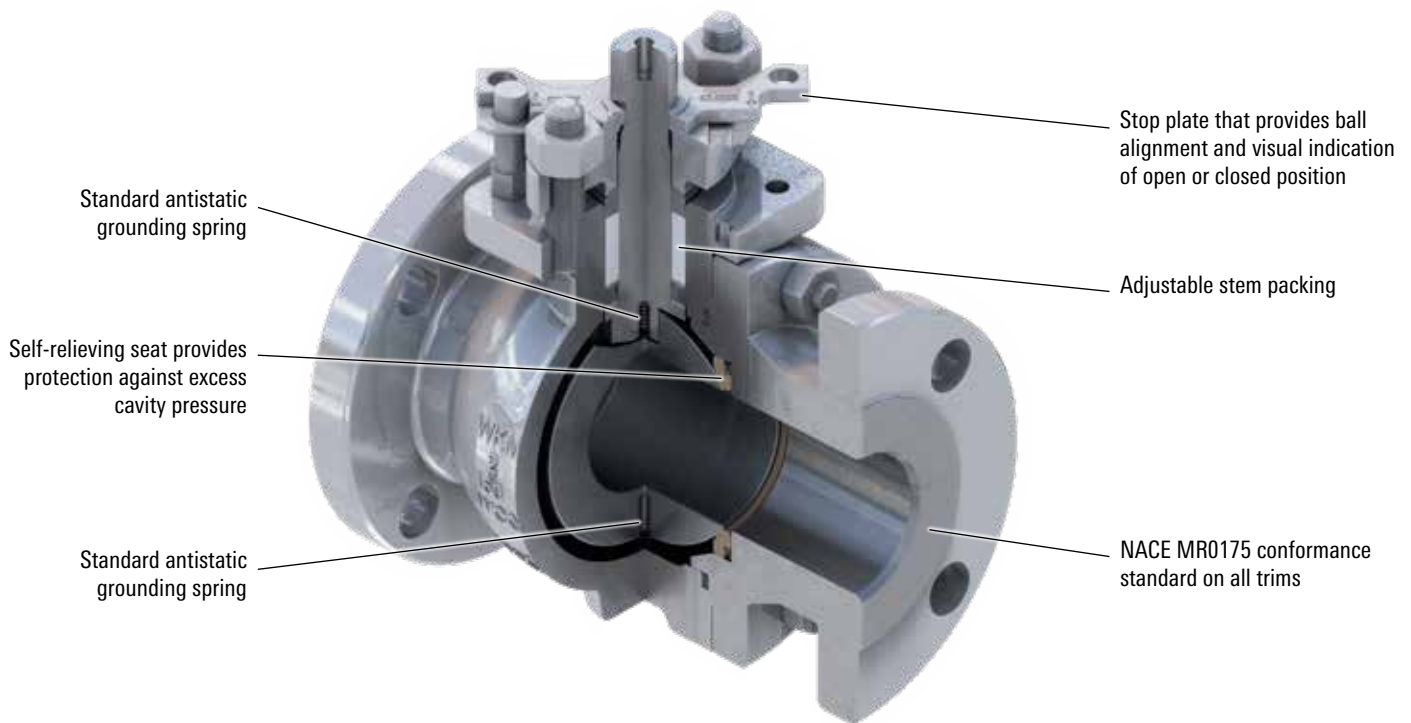

WKM 320F\* flanged floating ball valves satisfy a wide range of applications. Available in a variety of standard and optional materials, the valves are engineered for heavy-duty, maintenance-free performance and serve a variety of applications in virtually any industry.

### Chemical and petrochemical plants

There is a wide range of chemical and petrochemical applications for WKM 320F ball valves. They serve in plastic plants, handling such slurries as 40% vinyl chloride in high-pressure catalyst lines, and in processes, handling dry lading such as polyethylene and polystyrene powders.

### Refining

The WKM 320F ball valve is ideal for the refining industry. The many seats, seals, and trims available offer the versatility to handle the wide variety of products used in the refining process.

### Low-temperature service

Standard trims accommodate temperatures to  $-20$  degF [ $-29$  degC], and temperature trims are available to  $-50$  degF [ $-46$  degC].

### Maintenance-free performance

Under most conditions, the WKM 320F ball valve will provide years of trouble-free service with no maintenance required. In some severe applications, such as handling extremely abrasive slurries at high temperature, it may be necessary to replace the seats occasionally. Seat and seal kits are available, and replacement can be done easily with ordinary tools.

### Sour oil and gas service

WKM\* valves have served for years in gathering lines, manifolds, and field processing units in sour oil and gas fields. All trim combinations conform with NACE MR0175/ISO 15156.

## Features and Benefits

### Self-relieving seats

A patent-pending seat design provides automatic cavity relief without requiring a vented ball or external relief valve. API Spec 6D monogram is available upon request.

### Actuation friendly

A variety of actuator types, including pneumatic, hydraulic, diaphragm, vane, electromechanical, and electrohydraulic, can be easily installed.

### Fire tested for safety

All WKM 320F ball valves are qualified under API Standard 607 7th Ed. The seat and locked-in stem design contributes to its fire-tested characteristics. Should the soft seats be destroyed by fire, the ball floats downstream, providing a tight metal-to-metal seal against the lip of the seat pocket. If the tailpiece seals are destroyed, the metal-to-metal tailpiece-to-body connection retards external leakage.

### Adjustable, replaceable packing

The inline valve stem packing options consist of PTFE and graphite. The packing is field adjustable and virtually never requires lubrication.

### Fugitive emissions

WKM 320F ball valves can be supplied and certified to meet the requirements of fugitive emissions (FE) as regulated by ISO and API.

### Positively retained stem

The stem is positively retained and cannot be removed with the valve in service.

### Tight-sealing floating ball design

The ground, polished ball is free to float and mates perfectly with the conical seats for a positive, leak-proof seal. Self-cleaning and self-adjusting, the ball also is pressure activated—the higher the line pressure, the tighter the seal.

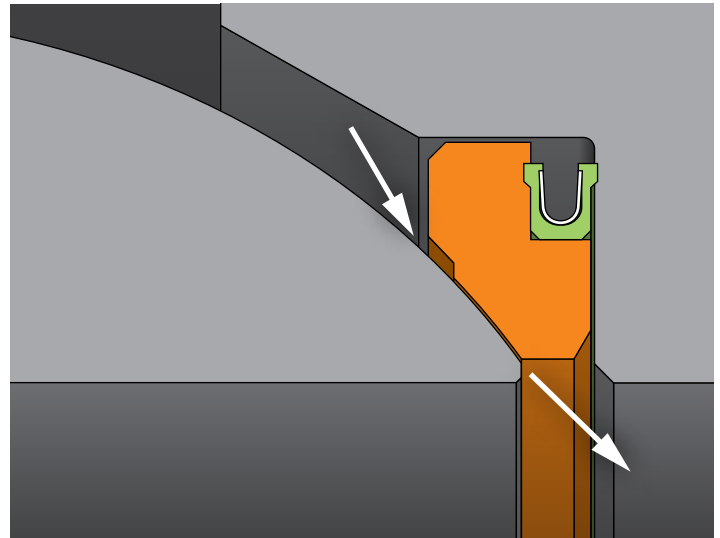

*Seat that relieves excess cavity pressure to the upstream side of the valve.*

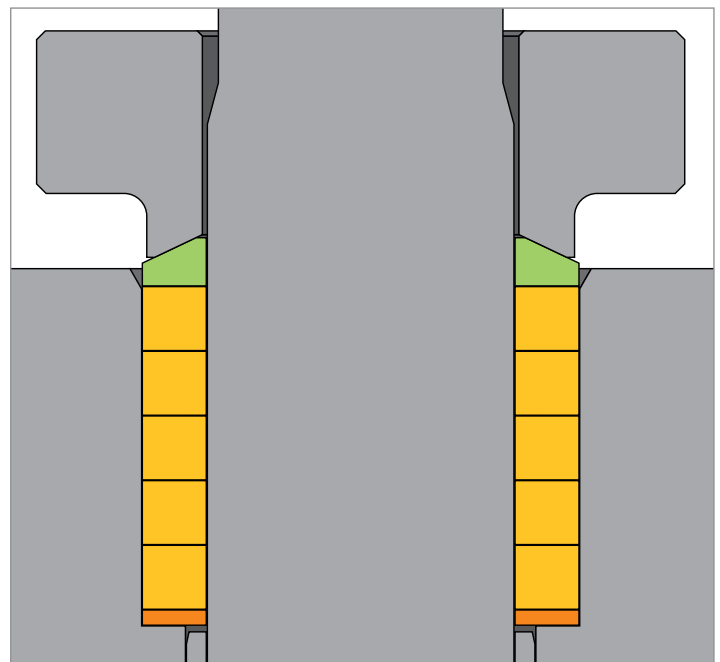

*Fugitive-emissions packing arrangement.*

# Specifications

## ASME Classes 150 through 600

### Operating temperatures

- From -50 to 500 degF [-46 to 260 degC]

### Standard material

- Body
  - Carbon steel and stainless steel
- Ball and stem
  - Carbon steel and stainless steel
  - Optional materials available upon request

### Industry compliance

- American Society of Mechanical Engineers (ASME) Standards B16.5 and B16.34
- Manufacturers Standardization Society Specifications MSS SP-25, 55, and 72
- API Spec 607 7th Ed. fire-test specification
- Canadian Registration Number (CRN)
- API Spec 608
- NACE MR0175
- ANSI Standard B16.34
- API Spec 6D upon request
- ISO or API fugitive emissions upon request
- European Pressure Equipment Directive (PED/CE) available upon request

### Bill of Materials

Part No.	Quantity	Description
101	1	Body
102	1	Tailpiece
151	— <sup>†</sup>	Body stud
152	— <sup>†</sup>	Body nut
190	1	Spiral-wound (SW) gasket, body to tail
211	1	Ball
222	2	Seat
223	2	Seat lip seal
241	1	Stem
261	1	Packing set (PTFE or graphite)
301	2	Stem thrust washer
302	1	Stem bearing
311	1	Packing compression ring
312	1	Packing bonnet
313	2	Packing stud
314	2	Packing nut
322	1	Stop plate
323	1	Lock plate
324	2	Stop pin
331 <sup>†</sup>	1	Lever
352 <sup>†</sup>	1	Ground spring, stem to ball
353	1	Grounding plunger, ball to body
354	1	Retaining ring

<sup>†</sup>Quantities depend on size and pressure class.

<sup>†</sup>Not shown.

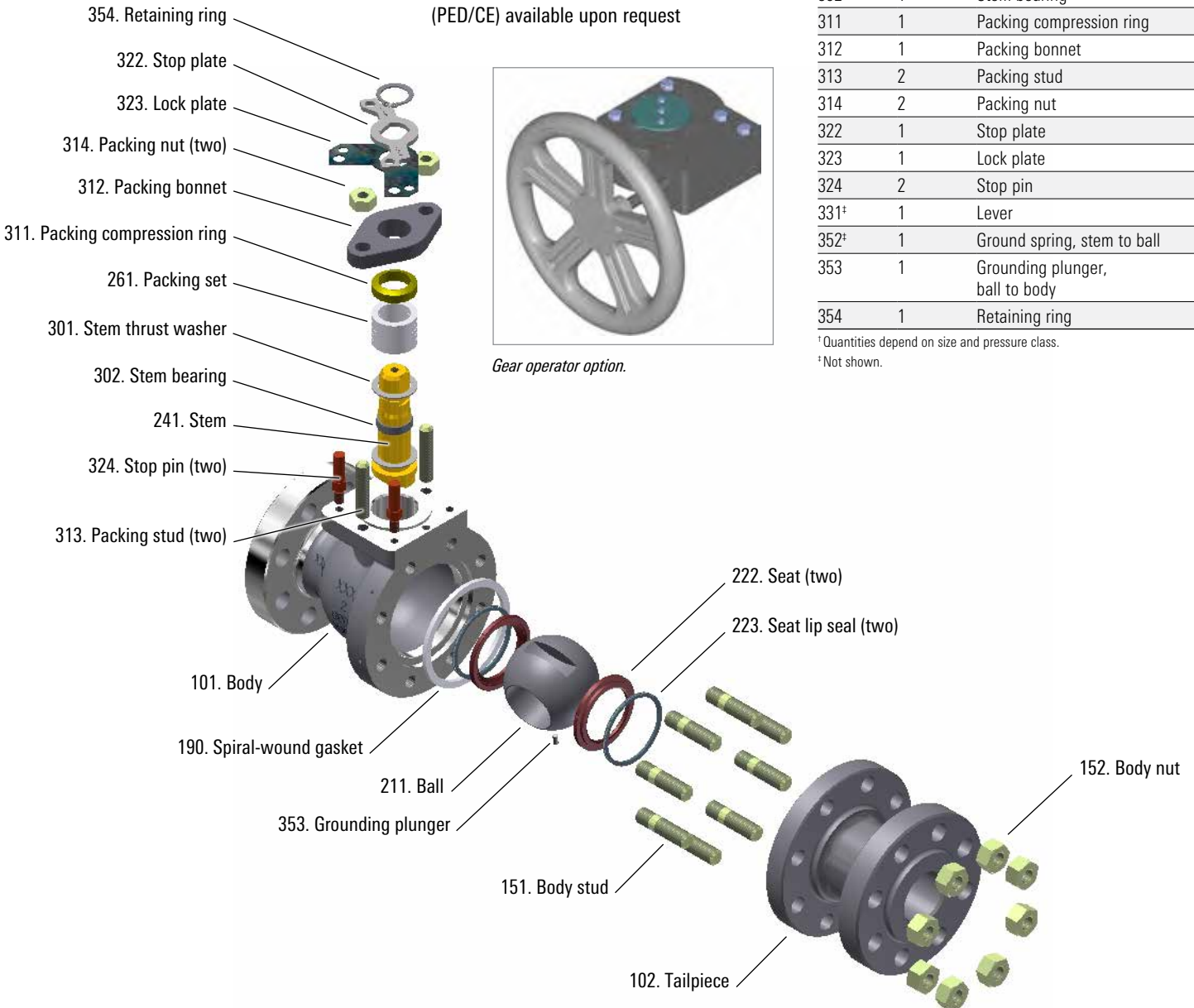

# Materials List

## Body Group Trim Number

Part	Carbon Steel (NACE) 24	Carbon Steel for Low Temperature (NACE) 37	Stainless Steel (NACE) 23	Carbon Steel with Coating (NACE) 26
Body	A216 Grade wrought carbon (WCC)	A352 Grade low-temperature wrought carbon (LCC)	A351 Grade CF8M	A216 Grade WCC, ZPEX® coating
Tailpiece	A216 Grade WCC	A352 Grade LCC	A351 Grade CF8M	A216 Grade WCC, ZPEX coating
Bonnet cap	Low alloy carbon steel (CS) zinc plated	Low alloy CS zinc plated	Low alloy CS zinc plated	Low alloy CS zinc plated
Studs	A320 Grade L7M zinc plated	A320 Grade L7M zinc plated	A320 Grade L7M zinc plated	A320 Grade L7M zinc plated <sup>†</sup>
Nuts	A194 Grade 7M zinc plated	A194 Grade 7M zinc plated	A194 Grade 7M zinc plated	A194 Grade 7M zinc plated <sup>†</sup>
Packing studs	A320 Grade L7M zinc plated	A320 Grade L7M zinc plated	A320 Grade L7M zinc plated	A320 Grade L7M zinc plated
Packing nuts	A194 Grade 7M zinc plated	A194 Grade 7M zinc plated	A194 Grade 7M zinc plated	A194 Grade 7M zinc plated

NACE indicates compliance with NACE MR0175/ISO 15156.

<sup>†</sup> ZPEX coating on studs and nuts available on request.

## Internal Group Trim Number

Ball	A105 CS ENP	— <sup>†</sup>	A351 CF8M or 316 SS	A105 CS ENP
Stem	A105 CS ENP	— <sup>†</sup>	316 stainless steel (SS)	A105 CS ENP
Ground spring	INCONEL® material	— <sup>†</sup>	INCONEL	INCONEL
Compression ring	316 SS	— <sup>†</sup>	316 SS	316 SS
Thrust washer	CS and TFE	— <sup>†</sup>	SS and TFE	CS and TFE

<sup>†</sup> Low-temperature model requires 23 stainless internal group.

## Seal Group Trim Code

Part	LTF	TTF	CGF	PGF
Temperature limits	–20 to 220 degF [–29 to 104 degC]	–50 to 300 degF [–46 to 149 degC]	–50 to 500 degF [–46 to 260 degC]	–50 to 500 degF [–46 to 260 degC]
Seat	Delrin® material	Filled PTFE	High-performance PTFE	PEEK
Packing	PTFE	PTFE	Graphite	Graphite
Body seal	Spiral-wound gasket Grafoil® and SS	Spiral-wound gasket Grafoil and SS	Spiral-wound gasket Grafoil and SS	Spiral-wound gasket Grafoil and SS

# Actuator Trim Codes

## Actuator Codes

Part (Body)	Worm Gear—For All Body Material Codes
Mounting bracket	Carbon steel
Bolting	Carbon steel
Set screw	Carbon steel
Stem adapter	Carbon steel
Actuator	As selected
Handwheel	Carbon steel

## Actuator Codes (Wrenches)

Part (Body)	Wrench—For All Body Material Codes
Wrench head	Steel
Wrench handle	Carbon steel
Wrench handle pin	Carbon steel
Capscrew	Alloy steel
Stop plate	Carbon steel

# How to Order

## Flanged (two-piece cast)

### Example

**2398031 1 1 2 1 1 2 3**

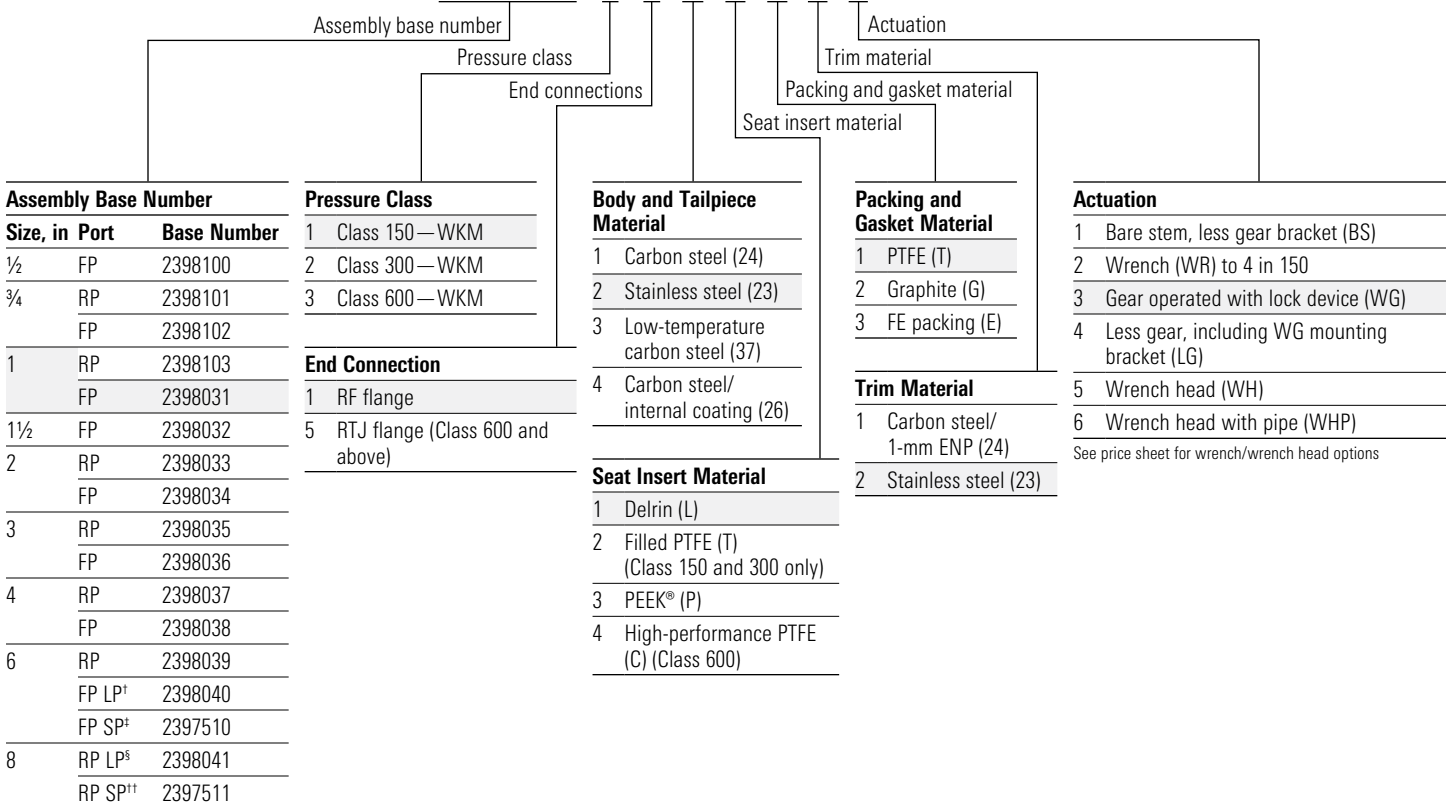

<sup>†</sup>LP CL 150–600

<sup>‡</sup>SP CL 150 only

<sup>§</sup>LP CL 150 and 600 only

<sup>¶</sup>SP 150 and 300 only

## Trim Codes

### Example

**2 320F 600 RF × RF 24 L T F 24 LG**

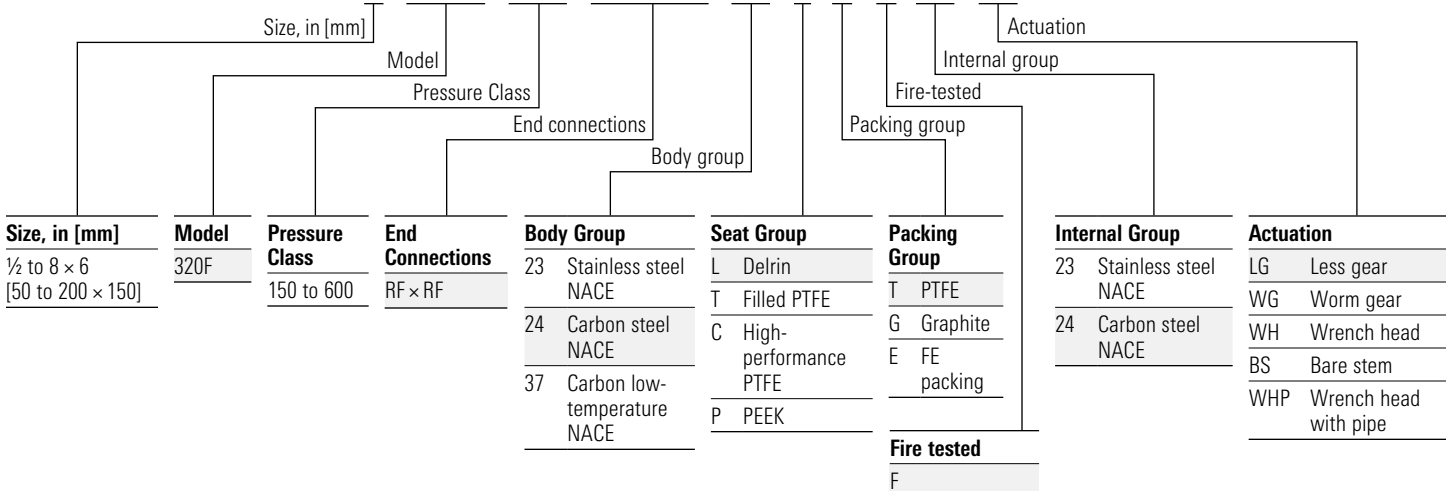

# Dimensional Data— $\frac{1}{2}$ -in Full Port Through 8-in $\times$ 6-in Reduced Port

$\frac{1}{2}$ -in full port through 8-in reduced port  
ASME Classes 150, 300, and 600

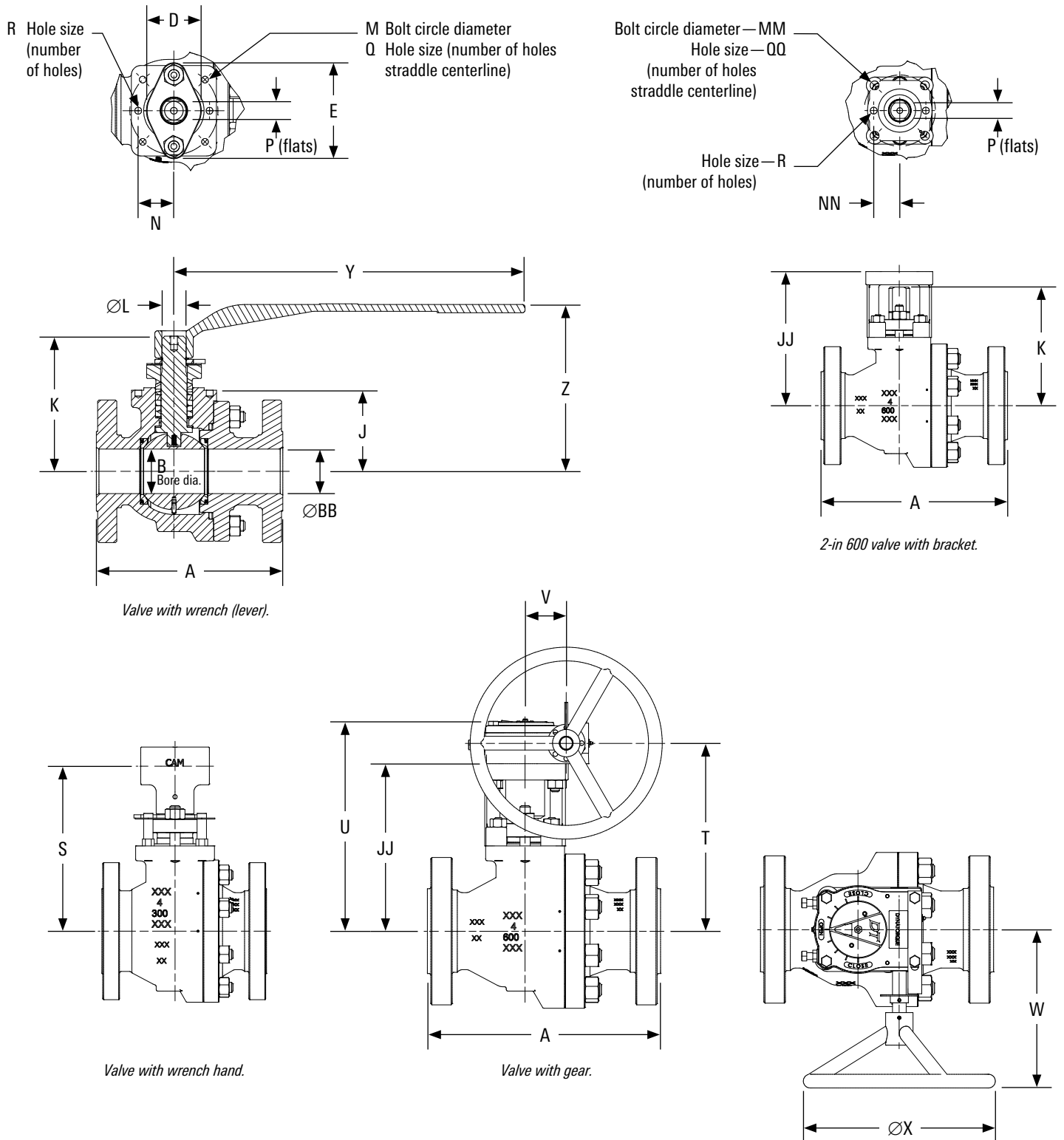

2-in 600 valve with bracket.

Valve with wrench (lever).

Valve with wrench hand.

Valve with gear.





# Dimensions

## WKM 320F Valve Class 600 Dimensions

Size, in [mm]	A		ØB	BB	D	E	J	JJ	K	ØL	ØM	MM	N	NN	P	ØQ	ØQQ	ØR	ØRR	S	T	U	V	W	X	Y	Z		
	RF	RJ																											
½ [13]	6.5 [165]	6.5 [165]	0.51 [13]	0.51 [13]	1.12 [28.5]	2.35 [59.7]	1.51 [38.4]	—	2.66 [67.6]	0.47 [11.9]	1.88 [47.6]	—	0.69 [17.5]	—	0.35 [8.92]	10-24 unc (4) 0.38 dp	—	0.125-(2) 0.19 dp	—	—	—	—	—	—	—	—	—	6 [152]	3.37 [85.6]
¾ × ½ [19 × 13]	7.5 [191]	7.5 [191]	0.51 [13]	0.76 [19.3]	1.12 [28.5]	2.35 [59.7]	1.51 [38.4]	—	2.66 [67.6]	0.47 [11.9]	1.88 [47.6]	—	0.69 [17.5]	—	0.35 [8.92]	10-24 unc (4) 0.38 dp	—	0.125-(2) 0.19 dp	—	—	—	—	—	—	—	—	—	6 [152]	3.37 [85.6]
¾ × ¾ [19 × 19]	7.5 [191]	7.5 [191]	0.76 [19.3]	0.76 [19.3]	1.25 [31.8]	2.66 [67.6]	1.80 [45.7]	—	3.34 [84.9]	0.55 [13.9]	2.13 [54]	—	0.81 [20.6]	—	0.43 [10.9]	0.25-(4) 0.44 dp	—	0.187-(2) 0.31 dp	—	—	—	—	—	—	—	—	—	8 [203]	4.18 [106]
1 × ¾ [25 × 19]	8.5 [216]	8.5 [216]	0.76 [19.3]	1.01 [25.7]	1.25 [31.8]	2.66 [67.6]	1.80 [45.7]	—	3.34 [84.9]	0.55 [13.9]	2.13 [54]	—	0.81 [20.6]	—	0.43 [10.9]	0.25-(4) 0.44 dp	—	0.187-(2) 0.31 dp	—	—	—	—	—	—	—	—	—	8 [203]	4.18 [106]
1 [25]	8.5 [216]	8.5 [216]	1.01 [26]	1.01 [25.7]	1.76 [44.7]	3.37 [85.6]	2.39 [61]	—	4.12 [105]	0.71 [18]	2.76 [70]	—	1.21 [31]	—	0.55 [14]	0.25-(4) 0.38 dp	—	0.19-(2) 0.31 dp	—	—	—	—	—	—	—	—	—	10 [254]	5.48 [139]
1½ [38]	9.5 [241]	9.5 [241]	1.51 [38]	1.51 [38.4]	2.24 [56.9]	3.88 [98.6]	3.08 [78]	—	5.27 [134]	0.86 [22]	3.38 [86]	—	1.38 [35]	—	0.67 [17]	0.38-(4) 0.63 dp	—	0.25-(2) 0.38 dp	—	—	—	—	—	—	—	—	—	12 [305]	6.89 [175]
2 × 1½ [50 × 38]	11.5 [292]	11.6 [295]	1.51 [38]	2.03 [51.6]	2.24 [56.9]	3.88 [98.6]	3.08 [78]	—	5.27 [134]	0.86 [22]	3.38 [86]	—	1.38 [35]	—	0.67 [17]	0.38-(4) 0.63 dp	—	0.25-(2) 0.38 dp	—	—	—	—	—	—	—	—	—	12 [305]	6.89 [175]
2 [50]	11.5 [292]	11.6 [295]	2.03 [51.6]	2.03 [51.6]	2.5 [63.5]	4.38 [111]	3.70 [94]	7.2 [183]	6.19 [157]	1.10 [28]	4.02 [102]	4.02 [102]	1.63 [41]	1.63 [41]	0.86 [22]	0.38-(4) 0.63 dp	0.44-(4) thru	0.31-(2) 0.38 dp	0.31-(2) 0.53 dp	—	8.3 [211]	9.85 [250]	1.75 [44.5]	9.08 [231]	6 [152]	16 [406]	7.61 [193]		
3 × 2 [80 × 50]	14 [356]	14.1 [359]	2.03 [51.6]	3.03 [77]	2.5 [63.5]	4.38 [111]	3.70 [94]	7.2 [183]	6.19 [157]	1.10 [28]	4.02 [102]	4.02 [102]	1.63 [41]	1.63 [41]	0.86 [22]	0.38-(4) 0.63 dp	0.44-(4) thru	0.31-(2) 0.38 dp	0.31-(2) 0.53 dp	—	8.3 [211]	9.85 [250]	1.75 [44.5]	9.08 [231]	6 [152]	16 [406]	7.61 [193]		
3 [80]	14 [283]	14.1 [359]	3.03 [77]	3.03 [77]	3 [76.2]	5.38 [137]	5.14 [131]	9.76 [248]	8.57 [217]	1.41 [36]	4.92 [125]	4.92 [125]	1.94 [49]	1.94 [49]	1.06 [27]	0.50-(4) 0.75 dp	0.56-(4) thru	0.44-(2) 0.63 dp	0.44-(2) 0.63 dp	9.56 [243]	11.1 [283]	12.8 [326]	2.51 [63.8]	12.2 [310]	12 [305]	24 [610]	10.8 [273]		
4 × 3 [100 × 80]	17 [432]	17.1 [435]	3.03 [77]	4.08 [104]	3 [76.2]	5.38 [137]	5.14 [131]	9.76 [248]	8.57 [217]	1.41 [36]	4.92 [125]	4.92 [125]	1.94 [49]	1.94 [49]	1.06 [27]	0.50-(4) 0.75 dp	0.56-(4) thru	0.44-(2) 0.63 dp	0.44-(2) 0.63 dp	9.56 [243]	11.3 [286]	13.0 [331]	3 [76.2]	11.7 [297]	12 [305]	24 [610]	10.8 [273]		
4 [100]	17 [432]	17.1 [435]	4.03 [102]	4.03 [102]	3.5 [88.9]	6.25 [159]	6.22 [158]	12.2 [310]	10.8 [275]	1.89 [48]	5.51 [140]	6.5 [165]	2.38 [60]	2.38 [60]	1.41 [36]	0.63-(4) 1.00 dp	0.81-(4) thru	0.63-(2) 0.75 dp	0.63-(2) 0.81 dp	12.1 [306]	13.7 [348]	15.5 [393]	3 [76.2]	11.6 [294]	14 [356]	—	—		
6 × 4 [150 × 100]	22 [559]	22.1 [562]	4.03 [102]	6.00 [152]	3.5 [88.9]	6.25 [159]	6.22 [158]	12.2 [310]	10.8 [275]	1.89 [48]	5.51 [140]	6.5 [165]	2.38 [60]	2.38 [60]	1.41 [36]	0.63-(4) 1.00 dp	0.81-(4) thru	0.63-(2) 0.75 dp	0.63-(2) 0.81 dp	12.1 [306]	13.7 [348]	15.5 [393]	3 [76.2]	11.6 [294]	14 [356]	—	—		
6 [150]	22 [559]	22.13 [562]	6.00 [152]	6.00 [152]	4.25 [108]	7.75 [197]	15.4 [392]	15.4 [392]	14.1 [358]	2.36 [60]	6.5 [165]	6.5 [165]	3 [76]	3 [76]	—	0.75-(4) 0.81 dp	0.81-(4) thru	0.75-(2) 1.00 dp	0.75-(2) 1.06 dp	—	17.1 [433]	18.98 [482]	3.63 [92.1]	13.2 [336]	20 [508]	—	—		
8 × 6 [200 × 150]	26 [660]	—	6.00 [152]	8.06 [205]	4.25 [108]	7.75 [197]	15.4 [392]	15.4 [392]	14.1 [358]	2.36 [60]	6.5 [165]	6.5 [165]	3 [76]	3 [76]	—	0.75-(4) 0.81 dp	0.81-(4) thru	0.75-(2) 1.00 dp	0.75-(2) 1.06 dp	—	17.1 [433]	18.98 [482]	3.63 [92.1]	13.2 [336]	20 [508]	—	—		

# Torque Estimation and MAST

Delrin or Teflon® Seat with Teflon Stem Packing					
Valve Port Size, in [mm]	Pressure Class	Gauge Pressure (P), psi	Run Torque at Max. P, in.lbf	Break Torque at Max. P, in.lbf	MAST <sup>1</sup> , in.lbf
½ [12.7]	150	80–290	11	20	228
	300	286–750	14	31	228
	600	741–1,500	19	45	228
¾ [19.05]	150	80–290	17	37	228
	300	286–750	27	65	401
	600	741–1,500	37	97	401
1 [25]	150	80–290	29	69	401
	300	286–750	52	125	881
	600	741–1,500	73	187	881
1½ [38.1]	150	80–290	67	185	881
	300	286–750	117	335	1,549
	600	741–1,500	164	506	1,549
2 [50]	150	80–290	136	385	1,549
	300	286–750	215	677	3,290
	600	741–1,500	301	1,026	3,290
3 [80]	150	80–290	301	1,037	3,290
	300	286–750	498	1,865	6,944
	600	741–1,500	696	2,843	6,944
4 [100]	150	80–290	611	2,158	6,944
	300	286–750	995	3,866	16,747
	600	741–1,500	1,392	5,899	16,747
6 [150]	150	80–290	1,562	6,013	16,747
	300	286–750	2,439	10,699	40,040
	600	741–1,500	3,372	16,339	40,040

<sup>1</sup>Maximum allowable stem torque (MAST).

Delrin or Teflon Seat with Graphite Stem Packing					
Valve Port Size, in [mm]	Pressure Class	Gauge Pressure (P), psi	Run Torque at Max. P, in.lbf	Break Torque at Max. P, in.lbf	MAST, in.lbf
½ [12.7]	150	80–290	42	51	228
	300	286–750	45	61	228
	600	741–1,500	49	74	228
¾ [19.05]	150	80–290	48	68	228
	300	286–750	88	126	401
	600	741–1,500	94	154	401
1 [25]	150	80–285	90	129	401
	300	286–740	183	256	881
	600	741–1,480	196	311	881
1½ [38.1]	150	80–285	198	315	881
	300	286–740	391	609	1,549
	600	741–1,480	423	764	1,549
2 [50]	150	80–285	410	659	1,549
	300	286–740	652	1,114	3,290
	600	741–1,480	713	1,438	3,290
3 [80]	150	80–285	738	1,474	3,290
	300	286–740	1,367	2,734	6,944
	600	741–1,480	1,516	3,662	6,944
4 [100]	150	80–285	1,480	3,027	6,944
	300	286–740	2,540	5,411	16,747
	600	741–1,480	2,850	7,356	16,747
6 [150]	150	80–285	3,108	7,559	16,747
	300	286–740	5,343	13,603	40,040
	600	741–1,480	6,110	19,077	40,040

## Weights

Valve Size, in [mm]	Weight, lbm [kg]		
	150	300	600
½ [12.7]	5.6 [2.5]	7.6 [3.4]	9.0 [4.1]
¾ × ½ [19.05 × 12.7]	6.6 [3]	9.9 [4.5]	11.7 [5.3]
¾ × ¾ [19.05 × 19.05]	7.2 [3.3]	11.7 [5.3]	14.3 [6.5]
1 × ¾ [25 × 19.05]	8.4 [3.8]	13.2 [6]	16.3 [7.4]
1 [25]	9.7 [4.4]	17.1 [7.8]	22.9 [10.4]
1½ [38]	20.1 [9.1]	32.1 [14.5]	40.9 [18.5]
2 × 1½ [50 × 38]	24.4 [11.1]	37.1 [16.8]	46.9 [21.3]
2 [50]	33.4 [15.1]	44.4 [20.1]	57.3 [26]
3 × 2 [80 × 50]	44.3 [20.1]	63.3 [28.7]	80.2 [36.3]
3 [80]	82.5 [37.4]	96.8 [43.9]	118.6 [53.7]
4 × 3 [100 × 80]	73.1 [33.1]	118.9 [53.9]	165.4 [74.9]
4 [100]	110.0 [49.8]	162.2 [73.5]	236.3 [107]
6 × 4 [150 × 100]	132.9 [60.2]	213.2 [96.6]	335.6 [152]
6 [150]	251.2 [113.8]	332.9 [150.8]	487.8 [221]
8 × 6 [200 × 150]	356 [161.5]	452.6 [205.3]	599.7 [271.7]

# WKM 320F



[cameron.slb.com/valves](https://cameron.slb.com/valves)

\*Mark of Schlumberger  
Other company, product, and service names  
are the properties of their respective owners.  
Copyright © 2019 Schlumberger. All rights reserved. 19-VL-538043

 **CAMERON**  
A Schlumberger Company