

GROVE B4, B5, and B7 Side-Entry Ball Valves

TECHNOLOGY



Table of Contents

GROVE B4, B5, AND B7 SIDE-ENTRY BALL VALVES

Features and Benefits

Applications.....	1
GROVE B4	
Design Features	2
Materials Specifications.....	4
Optional Features	5
Special Applications.....	6
GROVE B4-B4.D	
Valve Assembly and Cross Section.....	7
Dimensions and Weights	8
GROVE B5	
Design Features	11
Valve Assembly and Cross Section.....	14
Dimensions and Weights	15
GROVE B7	
Design Features	21
GROVE B7.B	
Valve Assembly and Cross Section.....	22
GROVE B7.1 AND B7.B	
Dimensions and Weights	23
Quality System	24
Qualification Testing	25
Services for Valves and Actuation	26
Trademark Information	27

GROVE B4, B5, & B7 Side-entry Ball Valves

FEATURES AND BENEFITS

Cameron's Valves & Measurement business segment is a leading provider of valves, valve automation, and measurement systems to the oil and gas industry.

We provide large-diameter valves for use in natural gas, LNG, crude oil, and refined products transmission lines as well as in many other general industrial applications.

Rigorously tested, field-proven, and backed by our services team, Cameron's GROVE® valves are among the best known valves in the world.

Applications

GROVE split-body side-entry ball valves are manufactured in a wide range of diameters and pressure classes.

In the standard versions, the valves are specified for transmission pipelines, pumping, compression and reinjection units, offshore platforms, onshore terminals, pig traps, measuring stations, and surge-relief skids.

These valves also can be built for speciality applications, such as subsea installations and LNG plants.

Split-body construction allows the use of forged materials in various grades of carbon steel, stainless steel, and high alloys, equipping the valves for some of the most severe service conditions.



Size		ASME CLASS						
(in.)	(mm)	150	300	400	600	900	1500	2500
1-1/2	(40)	●	●	●	●	●	●	▲
2	(50)	●	●	●	●	●	●	▲
3	(80)	●	●	●	●	●	●	▲
4	(100)	●	●	●	●	●	●	▲
6	(150)	■	■	■	■	■	■	▲
8	(200)	■	■	■	■	■	■	◆
10	(250)	■	■	■	■	■	■	◆
12	(300)	■	■	■	■	■	■	◆
14	(350)	■	■	■	■	■	■	◆
16	(400)	■	■	■	■	■	■	◆
18	(450)	■	■	■	■	■	■	◆
20	(500)	■	■	■	■	■	■	◆
22	(550)	■	■	■	■	■	■	
24	(600)	■	■	■	■	■	■	
26	(650)	■	■	■	■	■	■	
28	(700)	■	■	■	■	■	■	
30	(750)	■	■	■	■	■	■	
32	(800)	■	■	■	■	■	■	
34	(850)	■	■	■	■	■	■	
36	(900)	■	■	■	■	■	■	
40	(1000)	■	■	■	■	■	■	
42	(1050)	■	■	■	■	■	■	
46	(1150)	■	■	■	■	■	■	
48	(1200)	■	■	■	■	■	■	
56	(1400)	■	■	■	■	■	■	
60	(1500)	■	■	■	■	■	■	

B4 ● B5 ■ B7.1 ▲ B7.B ◆

GROVE B4

DESIGN FEATURES

Standard Features

The standard design valve code is B4.D.

- Double-barrier stem seals (the upper seal can be replaced with the valves in-line, under pressure, with the ball in the closed position)
- Short coupled trunnions reduce unit bearing loads and operating torque
- Factory-positioned external stops
- Stem separated from the ball; anti-blowout design; side load on stem
- Plastic polymer insert for seat sealing
- Self-relieving seats for ASME Classes 150 and 300
- Metal-backed, self-lubricating PTFE sleeve bearing and thrust washers reduce torque and extend service life
- Nickel plating for trim parts
- Fire-safe graphite rings for protection against external leakage



Options

According to the design impact of the optional features, the valve code may change to B4.B, B4.C, etc.

B4 – ALL TYPES

- PTFE various grades of reinforced gaskets, spring energized, for stem and seat sealing
- Antistatic device
- Metal-to-metal seats
- Double-sealing barrier in both directions (DPE) for ASME Classes 600, 900, and 1500; body relief valve for overpressure due to liquid thermal expansion
- Double block-and-bleed capabilities
- Explosive decompression-resistant seals

B4.B TYPE

When the valve design includes one or more of the following variations with respect to the standard design, the denomination becomes B4.B.

- Triple-barrier stem seals; upper stem seal O-ring replaceable with pressure in-line with the ball in the closed position
- Self-relieving seats

B4.C TYPE

This version of the B4 valves (in ASME Classes 600, 900, and 1500) features:

- O-ring seat seal
- Double-sealing barrier in both directions (DPE) and body pressure relief valve



Body Construction

The body is made of three forged parts, and the bolted construction allows disassembly in the field for repairs. The body drain is located in the lowest part of the body cavity and consists of a 1/4" NPT drain valve with safety plug. Graphite rings are provided for compliance with API 6FA and BS 6755 Part 2 fire-safe standards.

Stem Construction

The stem function is to transmit torque and to absorb the line pressure thrust together with the trunnion. The stem of Cameron's GROVE B4 valves has an anti-blowout design and incorporates a double-barrier system. The pressure thrust on the stem is supported by a thrust washer in antifriction material.

Seat Seal

The soft sealing between the seat and the ball is achieved by a plastic insert on B4.B, B4.D valves and by an O-ring on B4.C valves.

The block-and-bleed and double block-and-bleed capabilities are available as per API 6D definition on all types of B4 valves.

Self-relieving seats are standard on all B4.B, B4.C, and B4.D ASME Classes 150 and 300.

Independent sealing on upstream and downstream seats is available on B4.C and B4.D ASME Classes 600, 900, and 1500.

Ball Position

For valves normally mounted with lever, the ball open and closed positions are ensured by corresponding stops on the bearing housing. The lever position parallel to the line flow means the valve is open.

For valves with gears or actuators, the stops are set at the factory as primary stops. An "open/closed" indicator also is provided.



MATERIALS SPECIFICATIONS

Materials Selection

The design of the valve also depends on the materials of construction selected.

After examination of service conditions, the selection criteria are based on the verification of the physical and chemical characteristics of the materials or product.

For the soft sealing (O-rings, inserts, and lip seal gaskets), the guidelines to be followed are relevant for hardness, tensile strength, modulus, compression set, swelling, and fluid suitability.

The process is qualified so that the final thickness after machining can verify the chemical composition as per the relevant ASTM standard. The final check is carried out by the liquid penetrant method.

Weld Overlays

Sealing areas and other critical parts of the valve can be weld overlaid in case of corrosive service.

More frequently used materials are AISI 316L and Alloy 625.



Duplex Stainless Steels Metallurgy

On duplex (22 Cr to 2 Ni) and superduplex (25 Cr to 5 Ni) stainless steels, corrosion-resistance qualification check can be as follows:

- Chloride corrosion as per ASTM G48 (104° F or 40° C, 72 hours)
- Cracking as per ASTM G36 (302° F or 150° C, 500 hours)
- Pitting corrosion PRE = 33 min. for duplex, 40 min. for superduplex
- Ferrite content 40% to 60%, as per ASTM E562

NACE Requirements

On request, GROVE side-entry ball valves can be supplied in accordance with NACE MR0175.

Severe Wet Sour Gas Service

In addition to NACE MR0175, the additional qualifications can be:

- Sulfur \leq 0.015%
- Hydrogen-induced cracking as per NACE TM-02-84 (96 hours)
- Sulfide stress corrosion cracking as per NACE TM-01-77 (720 hours)



OPTIONAL FEATURES

Metal-to-Metal Seats

The contact area between the seats and the ball can be completely metallic. This feature is required when tight sealing is needed and the standard soft seal is no longer suitable due to the unfavorable combination of pressure, temperature, and chemical composition of the medium and/or when solid particles are present and when operating conditions prevail.

In case of metal-to-metal seats, the ball and seats coating can be obtained by means of various materials and processes, such as:

- Electroless nickel plating
- High-velocity application of carbide powder

When utilizing the metallic seats, it is necessary to verify the structure of the stem/ball coupling and the actuator choice, as there is an increase in the valve torque.

Transition Pieces

Cameron can weld transition pieces to the valve during the manufacturing process. Transition can be supplied by the customer or by Cameron to suit the customer's specifications.

Cameron offers a wide variety of weld procedures in accordance with international standards.

Stem Extensions

GROVE ball valves can be provided with optional stem extensions to permit buried or underground installations in remote or inaccessible areas.

When used for buried service, the stem extensions can be furnished watertight, and the piping of the grease injection system also will be extended.

When ordering extensions, please specify the distance required from the valve centerline to the handwheel centerline.

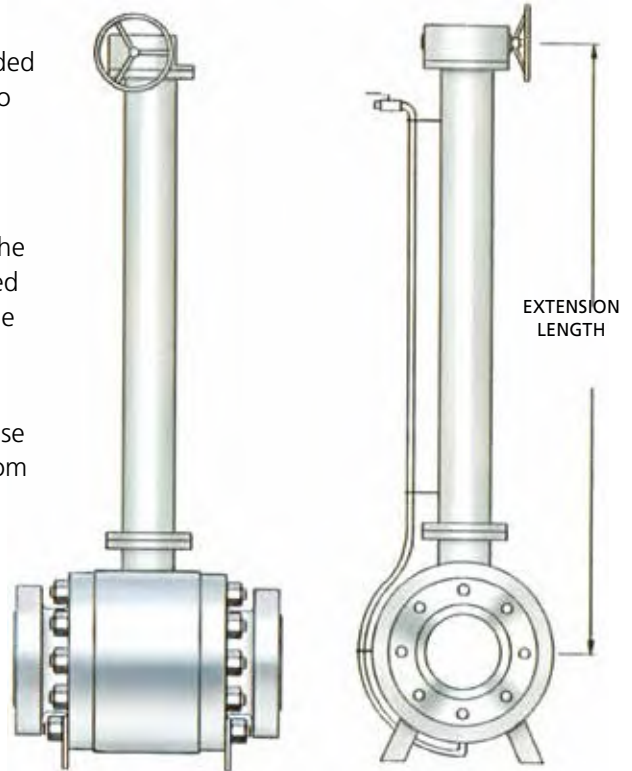

Other

Upon request, the valve can be furnished with specific adjustments for the installation with the horizontal stem.

Also upon request, the wrenches, gearboxes, and actuators can be supplied with locking devices to suit the customer's specifications.



SPECIAL APPLICATIONS

“S” Design for Subsea Service

The “S” valves are the subsea versions of the B4, B5, and B7 ball valves, specifically designed to suit subsea service conditions.

The “S” design takes into consideration the restrictive criteria used in the definition of safety coefficients relative to both pressure-retaining components and the stem connection between the valve and actuator, making the “S” valve suitable for EDS service.

The critical internal sealing surfaces are protected from corrosion resistance by the overlay, generally dictated by customer specifications and checked by chemical analysis of test specimens and the part(s).

The body is coated with special products and the body/ bonnet bolts are protected with special protective coatings and special sealing caps. The stem and external sealing areas are protected with additional seawater sealing gaskets.

The “S” valve is designed to be reliable and to provide optimum service with reduced maintenance. It usually is installed on modular rigs placed on the seafloor, complete with necessary components. When necessary, substitution or complete removal of these modules is possible.



“L” Design For Low-temperature Service

For certain gas treatment processes (e.g., LNG) and blowdown conditions, the valve must be able to limit the leakage within specified value and to ensure the maneuverability at a low temperature. The B4-L, B5-L, and B7-L valves are suitable for temperatures down to -184° F (-120° C).

The valves are referred to the respective standard types, but materials, parts dimensions, surface finishing, gaskets, and stem connections are specifically designed to suit low temperatures.

Epoxy-Phenolic Internal Coating

Cameron has developed a technology for anti-corrosive internal coatings. The products have been designed for oil brine, seawater and drinking water service, sour and corrosive applications.

The final thickness can be 180 to 350 microns. Hydrostatic shell testing is conducted before and after coating and thickness and holiday testing records are maintained.

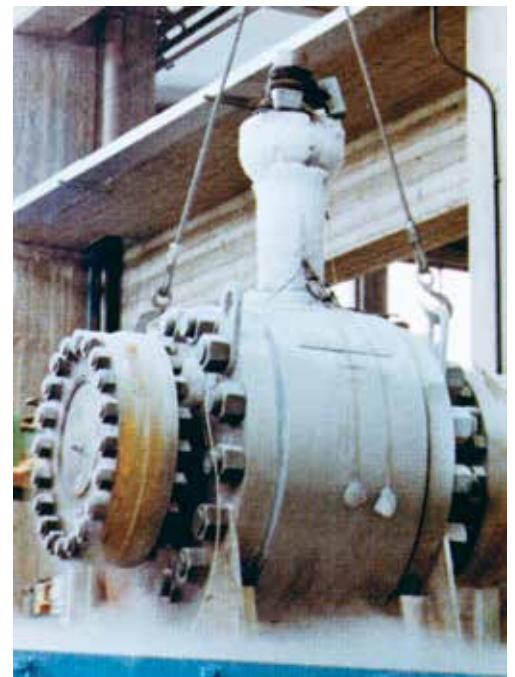

GROVE B4-B4.D

VALVE ASSEMBLY AND CROSS SECTION

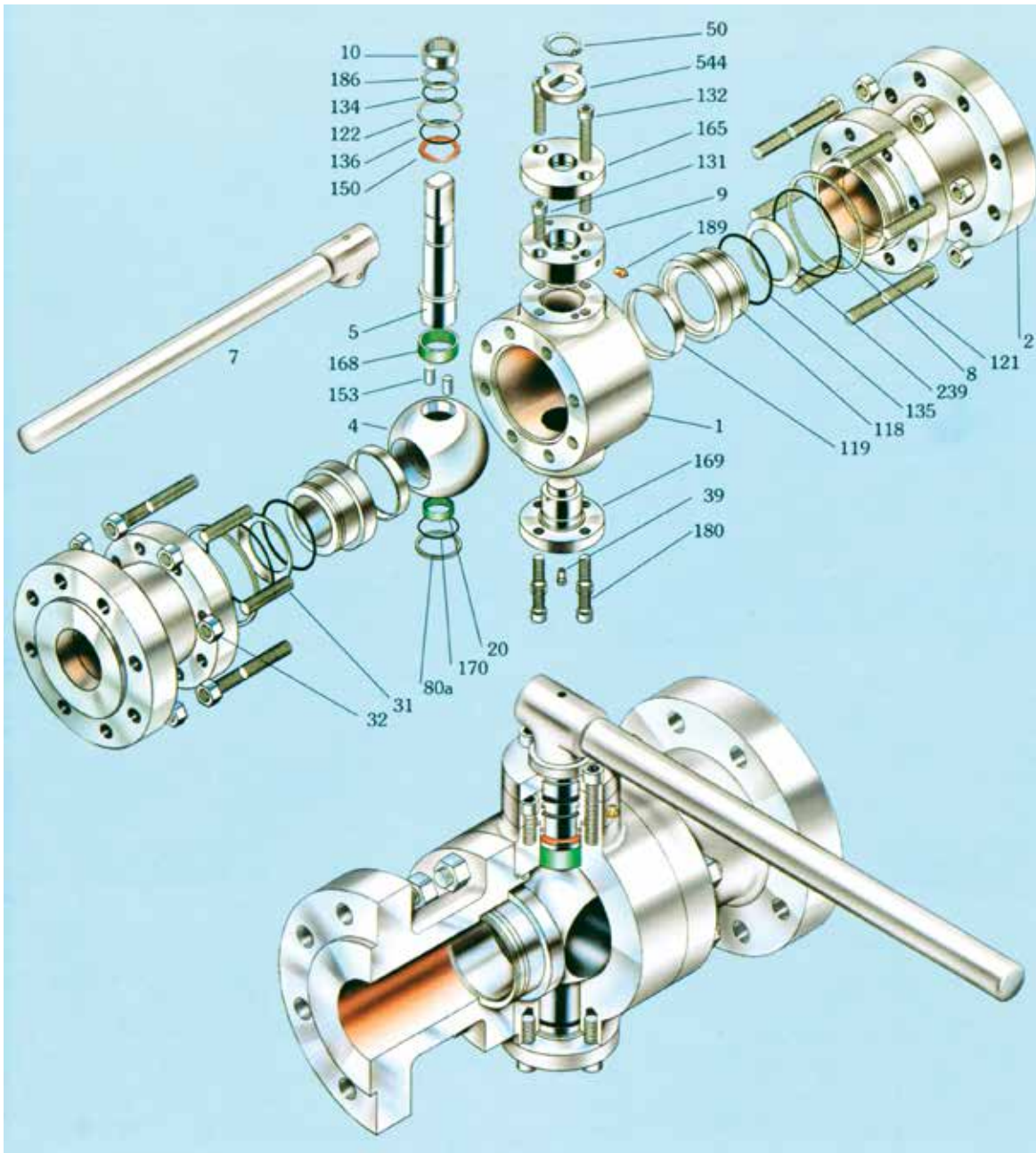

Item	Description	Item	Description	Item	Description
1	Body	39	Drain Valve	150	Upper Thrust Washer
2	Closure	50	Seeger Ring	153	Drive Pin
4	Ball	80a	Lower Trunnion Fire-safe Seal	165	Bearing Housing
5	Stem	118	Standard Seat Ring	168	Stem Bearing
7	Wrench Unit	119	Seat Insert	169	Lower Trunnion
8	Closure O-ring	121	Closure Fire-safe Seal	170	Trunnion O-ring
9	Gland Plate	122	Gland Plate Fire-safe Seal	180	Lower Trunnion Capscrew
10	Gland Bushing	131	Gland Plate Capscrew	186	Stem Fire-safe Packing
20	Trunnion Bearing	132	Bearing Housing Capscrew	189	Gland Vent
31	Body Stud	134	Stem O-ring	239	Spring Washer
32	Body Stud Nut	135	Seat Gasket O-ring	544	Stop Collar
		136	Gland Plate O-ring		

DIMENSIONS AND WEIGHTS

ASME CLASS 150

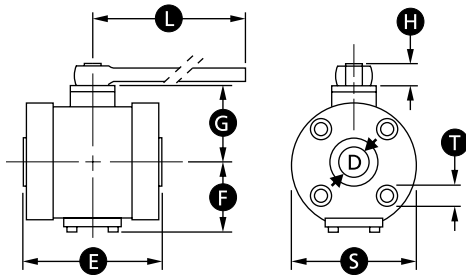

Size (in.)	Thread	T (in.) Depth	Flange Holes (No.)
1-1/2	1/2 UNC	13/16	4
2	5/8 UNC	15/16	4
3	5/8 UNC	15/16	4
4	5/8 UNC	15/16	8

ASME CLASS 300

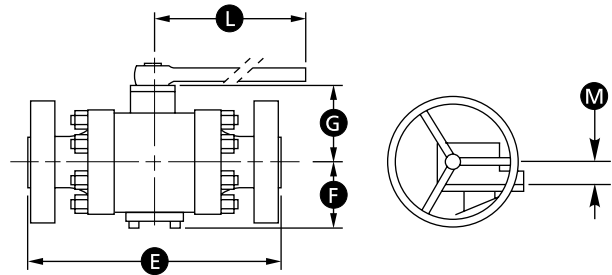

ASME CLASS 150

SIZE	in. (mm)	D	E			F	G	S	H	L	A	K	M	WEIGHT	
			WE	RF	RTJ									WE	RF/RTJ
1-1/2 (40)	1-1/2 (38)	7-1/2 (191)	6-1/2 (165)	7 (178)	3-7/8 (98)	4-1/4 (108)	5 (127)	7/8 (22)	10-3/4 (273)	-	-	-	29 (13)	31 (14)	
2 x 1-1/2 x 2 (50 x 40 x 50)	1-1/2 (38)	8-1/2 (216)	7 (178)	7-1/2 (191)	3-7/8 (98)	4-1/4 (108)	5 (127)	7/8 (22)	10-3/4 (273)	-	-	-	31 (14)	40 (18)	
2 (50)	2 (51)	8-1/2 (216)	7 (178)	7-1/2 (191)	4-1/8 (105)	4-5/8 (118)	5-5/8 (143)	7/8 (22)	12-5/8 (321)	-	-	-	37 (17)	51 (23)	
3 x 2 x 3 (80 x 50 x 80)	2 (51)	11-1/8 (283)	8 (203)	8-1/2 (216)	4-1/8 (105)	4-5/8 (118)	5-5/8 (143)	7/8 (22)	12-5/8 (321)	-	-	-	53 (24)	60 (27)	
3 (80)	3 (76)	11-1/8 (283)	8 (203)	8-1/2 (216)	5-1/8 (130)	5-5/8 (143)	7-3/4 (197)	1-1/8 (28)	16-1/2 (419)	-	-	-	84 (38)	95 (43)	
4 x 3 x 4 (100 x 80 x 100)	3 (76)	12 (305)	9 (229)	9-1/2 (241)	5-1/8 (130)	5-5/8 (143)	7-3/4 (197)	1-1/8 (28)	16-1/2 (419)	-	-	-	86 (39)	104 (47)	
4 (100)	4 (102)	12 (305)	9 (229)	9-1/2 (241)	6-1/8 (155)	6-5/8 (168)	9-3/8 (238)	1-1/8 (28)	20-1/4 (514)	-	-	-	123 (56)	146 (66)	
6 x 4 x 6 (150 x 100 x 150)	4 (102)	18 (457)	15-1/2 (394)	16 (406)	6-1/8 (155)	6-5/8 (168)	9-3/8 (238)	1-1/8 (28)	20-1/4 (514)	-	-	-	152 (69)	161 (73)	

ASME CLASS 300

SIZE	in. (mm)	D	E			F	G	S	H	L	A	K	M	WEIGHT	
			WE	RF	RTJ									WE	RF/RTJ
1-1/2 (40)	1-1/2 (38)	7-1/2 (191)	7-1/2 (191)	8 (203)	3-7/8 (98)	4-1/4 (108)	5 (127)	7/8 (22)	10-3/4 (273)	-	-	-	29 (13)	40 (18)	
2 x 1-1/2 x 2 (50 x 40 x 50)	1-1/2 (38)	8-1/2 (216)	8-1/2 (216)	9-1/8 (232)	3-7/8 (98)	4-1/4 (108)	5 (127)	7/8 (22)	10-3/4 (273)	-	-	-	31 (14)	44 (20)	
2 (50)	2 (51)	8-1/2 (216)	8-1/2 (216)	9-1/8 (232)	4-1/8 (105)	4-5/8 (118)	5-5/8 (143)	7/8 (22)	14-5/8 (372)	-	-	-	37 (17)	51 (23)	
3 x 2 x 3 (80 x 50 x 80)	2 (51)	11-1/8 (283)	11-1/8 (283)	11-3/4 (298)	4-1/8 (105)	4-5/8 (118)	5-5/8 (143)	7/8 (22)	14-5/8 (372)	-	-	-	53 (24)	75 (34)	
3 (80)	3 (76)	11-1/8 (283)	11-1/8 (283)	11-3/4 (298)	5-1/8 (130)	5-5/8 (143)	7-3/4 (197)	1-1/8 (28)	22-3/8 (568)	-	-	-	88 (40)	117 (53)	
4 x 3 x 4 (100 x 80 x 100)	3 (76)	12 (305)	12 (305)	12-5/8 (321)	5-1/8 (130)	5-5/8 (143)	7-3/4 (197)	1-1/8 (28)	22-3/8 (568)	-	-	-	90 (41)	123 (56)	
4 (100)	4 (102)	12 (305)	12 (305)	12-5/8 (321)	6-1/8 (155)	6-5/8 (168)	9-3/8 (238)	1-1/8 (28)	26-1/8 (664)	-	-	-	128 (58)	170 (77)	
6 x 4 x 6 (150 x 100 x 150)	4 (102)	18 (457)	15-7/8 (403)	16-1/2 (419)	6-1/8 (155)	6-5/8 (168)	9-3/8 (238)	1-1/8 (28)	26-1/8 (664)	-	-	-	165 (75)	223 (101)	

Flanges in accordance with ASME B16.5

Shaded bore sizes (D) according to API 6D

Shaded end-to-end dimensions (E) according to API 6D

Butt welding ends according to ASME B16.25

Outlined end-to-end dimensions (E) according to ASME B16.10

DIMENSIONS AND WEIGHTS (CONT.)

ASME CLASS 400

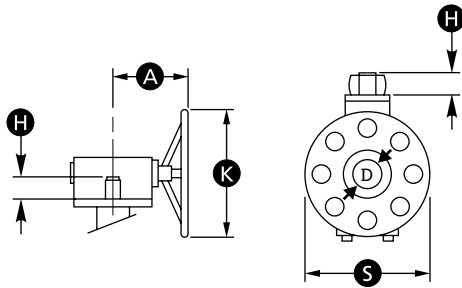

ASME CLASS 600

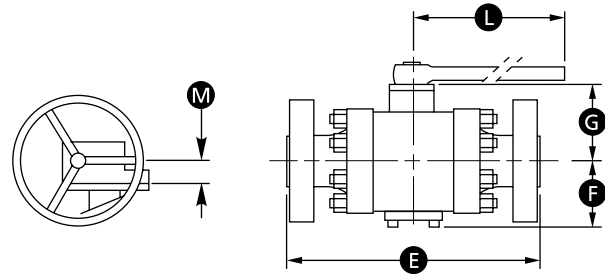

ASME CLASS 400

SIZE	in. (mm)	D	E			F	G	S	H	L	A	K	M	WEIGHT	
			WE	RF	RTJ									WE	RF/RTJ
1-1/2 (40)	1-1/2 (38)	1-1/2 (38)	9-1/2 (241)	9-1/2 (241)	9-1/2 (241)	3-7/8 (98)	4-1/4 (108)	5 (127)	7/8 (22)	10-3/4 (273)	-	-	-	30 (13)	43 (20)
2 x 1-1/2 x 2 (50 x 40 x 50)	1-1/2 (38)	1-1/2 (38)	11-1/2 (292)	11-1/2 (292)	11-5/8 (295)	3-7/8 (98)	4-1/4 (108)	5 (127)	7/8 (22)	10-3/4 (273)	-	-	-	33 (15)	49 (22)
2 (50)	2 (51)	2 (51)	11-1/2 (292)	11-1/2 (292)	11-5/8 (295)	4-1/8 (105)	4-5/8 (118)	5-5/8 (143)	7/8 (22)	14-5/8 (372)	-	-	-	41 (19)	56 (25)
3 x 2 x 3 (80 x 50 x 80)	2 (51)	2 (51)	14 (356)	14 (356)	14-1/8 (359)	4-1/8 (105)	4-5/8 (118)	5-5/8 (143)	7/8 (22)	14-5/8 (372)	-	-	-	56 (25)	80 (36)
3 (80)	3 (76)	3 (76)	14 (356)	14 (356)	14-1/8 (359)	5-1/8 (130)	5-5/8 (143)	7-3/4 (197)	1-1/8 (28)	22-3/8 (568)	-	-	-	93 (42)	123 (56)
4 x 3 x 4 (100 x 80 x 100)	3 (76)	3 (76)	16 (406)	16 (406)	16-1/8 (410)	5-1/8 (130)	5-5/8 (143)	7-3/4 (197)	1-1/8 (28)	22-3/8 (568)	-	-	-	103 (47)	146 (67)
4 (100)	4 (102)	4 (102)	16 (406)	16 (406)	16-1/8 (410)	6-1/8 (155)	6-5/8 (168)	9-3/8 (238)	1-1/8 (28)	26-1/8 (664)	-	-	-	146 (66)	198 (90)
6 x 4 x 6 (150 x 100 x 150)	4 (102)	4 (102)	19-1/2 (495)	19-1/2 (495)	19-5/8 (499)	6-1/8 (155)	6-5/8 (168)	9-3/8 (238)	1-1/8 (28)	26-1/8 (664)	-	-	-	179 (81)	279 (127)

ASME CLASS 600

SIZE	in. (mm)	D	E			F	G	S	H	L	A	K	M	WEIGHT	
			WE	RF	RTJ									WE	RF/RTJ
1-1/2 (40)	1-1/2 (38)	1-1/2 (38)	9-1/2 (241)	9-1/2 (241)	9-1/2 (241)	3-7/8 (98)	4-1/4 (108)	5 (127)	7/8 (22)	11-7/8 (302)	-	-	-	31 (14)	46 (21)
2 x 1-1/2 x 2 (50 x 40 x 50)	1-1/2 (38)	1-1/2 (38)	11-1/2 (292)	11-1/2 (292)	11-5/8 (295)	3-7/8 (98)	4-1/4 (108)	5 (127)	7/8 (22)	11-7/8 (302)	-	-	-	35 (16)	53 (24)
2 (50)	2 (51)	2 (51)	11-1/2 (292)	11-1/2 (292)	11-5/8 (295)	4-1/8 (105)	4-5/8 (118)	5-5/8 (143)	7/8 (22)	16-7/8 (429)	-	-	-	44 (20)	62 (28)
3 x 2 x 3 (80 x 50 x 80)	2 (51)	2 (51)	14 (356)	14 (356)	14-1/8 (359)	4-1/8 (105)	4-5/8 (118)	5-5/8 (143)	7/8 (22)	16-7/8 (429)	-	-	-	60 (27)	86 (39)
3 (80)	3 (76)	3 (76)	14 (356)	14 (356)	14-1/8 (359)	5-1/8 (130)	5-5/8 (143)	7-3/4 (197)	1-1/8 (28)	26-1/4 (667)	-	-	-	97 (44)	130 (59)
4 x 3 x 4 (100 x 80 x 100)	3 (76)	3 (76)	17 (432)	17 (432)	17-1/8 (435)	5-1/8 (130)	5-5/8 (143)	7-3/4 (197)	1-1/8 (28)	26-1/4 (667)	-	-	-	115 (52)	168 (76)
4 (100)	4 (102)	4 (102)	17 (432)	17 (432)	17-1/8 (435)	6-1/8 (155)	6-5/8 (168)	9-3/8 (238)	1-1/8 (28)	30-1/8 (765)	-	-	-	192 (87)	335 (152)
6 x 4 x 6 (150 x 100 x 150)	4 (102)	4 (102)	22 (559)	22 (559)	22-1/8 (562)	6-1/8 (155)	6-5/8 (168)	9-3/8 (238)	1-1/8 (28)	30-1/8 (765)	-	-	-	192 (87)	335 (152)

Flanges in accordance with ASME B16.5

Shaded bore sizes (D) according to API 6D

Shaded end-to-end dimensions (E) according to API 6D

Butt welding ends according to ASME B16.25

Outlined end-to-end dimensions (E) according to ASME B16.10

ASME CLASS 900 AND 1500

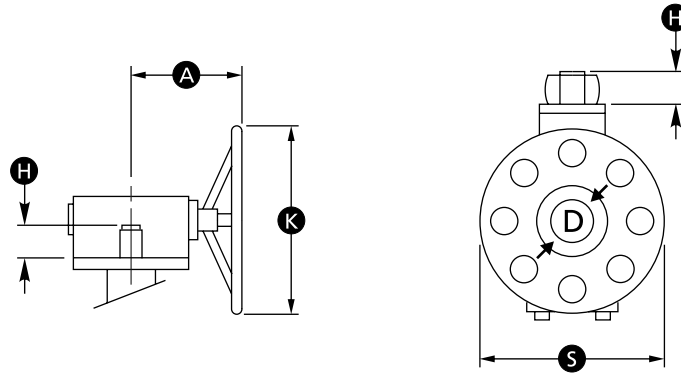

ASME CLASS 900

SIZE	in. (mm)	D	E			F	G	S	H	L	A	K	M	WEIGHT	
			WE	RF	RTJ									WE	RF/RTJ
1-1/2 (40)	1-1/2 (38)	12 (305)	12 (305)	12 (305)	4 (102)	4-1/2 (114)	5-1/8 (130)	7/8 (22)	13-1/2 (343)	-	-	-	-	44 (20)	68 (31)
2 x 1-1/2 x 2 (50 x 40 x 50)	1-1/2 (38)	14-1/2 (368)	14-1/2 (368)	14-5/8 (372)	4 (102)	4-1/2 (114)	5-1/8 (130)	7/8 (22)	13-1/2 (343)	-	-	-	-	49 (22)	95 (43)
2 (50)	2 (51)	14-1/2 (368)	14-1/2 (368)	14-5/8 (372)	4-1/2 (114)	4-7/8 (124)	6-3/8 (162)	7/8 (22)	22 (559)	-	-	-	-	77 (35)	130 (59)
3 x 2 x 3 (80 x 50 x 80)	2 (51)	15 (381)	15 (381)	15-1/8 (359)	4-1/2 (114)	4-7/8 (124)	6-3/8 (162)	7/8 (22)	22 (559)	-	-	-	-	108 (49)	143 (65)
3 (80)	3 (76)	15 (381)	15 (381)	15-1/8 (359)	5-5/8 (143)	6-1/8 (156)	8-3/8 (213)	1-1/8 (28)	35-7/8 (911)	-	-	-	-	157 (71)	187 (85)
4 x 3 x 4 (100 x 80 x 100)	3 (76)	18 (457)	18 (457)	18-1/8 (460)	5-5/8 (143)	6-1/8 (156)	8-3/8 (213)	1-1/8 (28)	35-7/8 (911)	-	-	-	-	159 (72)	240 (109)
4 (100)	4 (102)	18 (457)	18 (457)	18-1/8 (460)	6-7/8 (175)	7-1/2 (191)	11-1/2 (292)	2-1/8 (54)	-	10-7/8 (276)	23-5/8 (600)	1-3/4 (44)	-	353 (160)	390 (177)
6 x 4 x 6 (150 x 100 x 150)	4 (102)	24 (610)	24 (610)	24-1/8 (613)	6-7/8 (175)	7-1/2 (191)	10-1/4 (260)	2-1/8 (54)	-	10-7/8 (276)	23-5/8 (600)	1-3/4 (44)	-	357 (162)	489 (222)

ASME CLASS 1500

SIZE	in. (mm)	D	E			F	G	S	H	L	A	K	M	WEIGHT	
			WE	RF	RTJ									WE	RF/RTJ
1-1/2 (40)	1-1/2 (38)	12 (305)	12 (305)	12 (305)	4 (102)	4-1/2 (114)	5-1/8 (130)	7/8 (22)	15-7/8 (403)	-	-	-	-	44 (20)	68 (31)
2 x 1-1/2 x 2 (50 x 40 x 50)	1-1/2 (38)	14-1/2 (368)	14-1/2 (368)	14-5/8 (372)	4 (102)	4-1/2 (114)	5-1/8 (130)	7/8 (22)	15-7/8 (403)	-	-	-	-	49 (22)	95 (43)
2 (50)	2 (51)	14-1/2 (368)	14-1/2 (368)	14-5/8 (372)	4-1/2 (114)	4-7/8 (124)	6-3/8 (162)	7/8 (22)	24-1/4 (616)	-	-	-	-	77 (35)	130 (59)
3 x 2 x 3 (80 x 50 x 80)	2 (51)	18-1/2 (470)	18-1/2 (470)	18-5/8 (473)	4-1/2 (114)	4-7/8 (124)	6-3/8 (162)	7/8 (22)	24-1/4 (616)	-	-	-	-	108 (49)	168 (76)
3 (80)	3 (76)	18-1/2 (470)	18-1/2 (470)	18-5/8 (473)	5-5/8 (143)	6-1/8 (156)	8-3/8 (213)	2-1/8 (54)	-	6-3/4 (171)	11-3/4 (298)	1-1/4 (32)	-	179 (81)	240 (109)
4 x 3 x 4 (100 x 80 x 100)	3 (76)	21-1/2 (546)	21-1/2 (546)	21-5/8 (549)	5-5/8 (143)	6-1/8 (156)	8-3/8 (213)	2-1/8 (54)	-	6-3/4 (171)	11-3/4 (298)	1-1/4 (32)	-	185 (84)	311 (141)
4 (100)	4 (102)	21-1/2 (546)	21-1/2 (546)	21-5/8 (549)	6-7/8 (175)	7-1/2 (191)	12-1/4 (311)	2-1/8 (54)	-	10-7/8 (276)	23-5/8 (600)	1-3/4 (44)	-	355 (161)	399 (181)
6 x 4 x 6 (150 x 100 x 150)	4 (102)	27-3/4 (705)	27-3/4 (705)	28 (711)	6-7/8 (175)	7-1/2 (191)	10-1/4 (260)	2-1/8 (54)	-	10-7/8 (276)	23-5/8 (600)	1-3/4 (44)	-	366 (166)	628 (285)

Flanges in accordance with ASME B16.5

Shaded bore sizes (D) according to API 6D

Shaded end-to-end dimensions (E) according to API 6D

Butt welding ends according to ASME B16.25

Outlined end-to-end dimensions (E) according to ASME B16.10

GROVE B5

DESIGN FEATURES

Standard Features

- Double-barrier stem seals
- Stem separated from the ball; anti-blowout design; no side load on the stem
- Bearing blocks absorb the pressure load on the ball
- Primary metal-to-metal seal and secondary protected synthetic O-ring seal
- Double-sealing barrier in both directions (DPE)
- Body relief valve for overpressure due to liquid thermal expansion
- Built-in sealant injection system for emergency seat seal
- Metal-backed, self-lubricating PTFE sleeve bearing and thrust washers reduce torque and extend service life
- Nickel plating for trim parts
- Trunnion mounted ball for ease of operation at high pressure
- Large-diameter, short coupled trunnions to reduce unit bearing loads and operating torque
- Bolted construction permits disassembly in the field for repairs
- Integral stop in the adapter plate for a permanent reference to open and closed position
- Antistatic device

Options

- Triple-barrier stem seals
- Emergency grease fitting for stem
- Self-relieving seats
- Plastic polymer O-ring or insert for primary seat sealing
- Double block-and-bleed capabilities
- PTFE various grades of reinforced gaskets, spring energized, for stem and seat sealing
- Metal-to-metal seat
- Explosive decompression-resistant seal



DESIGN FEATURES (CONT.)

Body Construction

The body is made of three forged parts, and the bolted construction allows disassembly in the field for repairs. The bolts threads areas are per ISO metric or ASME imperial, depending on the market request. The tightening of the bolts is made by hydraulic tools with a predetermined torque. The body drain is located in the lowest part of the body cavity and consists of an NPT drain valve with safety plug.

Stem Construction

The stem of Cameron's GROVE B5 valve is separated from the ball and is connected to the upper ball trunnion by steel pins. Bearing blocks are located on the upper and lower ball trunnions, which absorb all the pressure load on the ball.

The stem is a free member and carries no side thrust. The absence of this side load and friction drag on the stem ensures lower operating torque and long service life.

The stem is sealed by means of two O-rings. If leakage should ever occur through both stem seals, the outer O-ring can be replaced with the valve in the line, under pressure with the ball in the closed position. With no pressure in-line, it is possible to remove the gland plate for replacement of both primary and outer stem O-rings. The stem also can be removed and replaced if necessary.

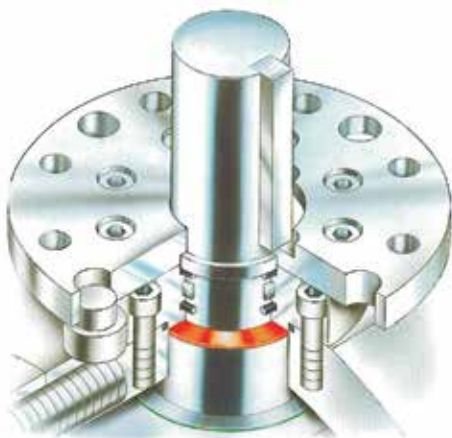

Torque

Cameron's GROVE B5 valve's low operating torque is due to a combination of factors:

- The design of the stem, which is separated from the ball
- The side loads, brought on by differential pressure, are absorbed by two (upper and lower) rigid bearing retainers and large-diameter, short coupled trunnions to reduce unit bearing loads
- The metal-backed, self-lubricating sleeve bearing and the thrust washers reduce the torque and extend service life

Ball Position

The ball's open and closed positions are ensured by corresponding stops on the adapter plate.

The valve normally is mounted with the actuator stops or the gear stops set at the factory as primary stops. An "open/closed" indicator also is provided.



Seat Seals

The GROVE B5 seat design ensures double-barrier sealing in both directions (the normal self-relieving seats are a simple barrier of sealing). The sealing is performed by both a primary metal-to-metal seal and a secondary protected O-ring seal.

Double Piston Effect (DPE)

The DPE seat design was invented and patented by Cameron's GROVE team. The DPE seat design allows for both seats to seal with pressure acting from the same side of the valve. In the event one seat becomes damaged, the user has the added advantage of the opposite seat sealing. By means of this double barrier, the sealing is ensured regardless of the direction of the flow through the valve.

If the upstream seat (1) becomes damaged and leaks, the pressure entering the body cavity acts on the downstream seat (2), sealing the downstream seat tightly against the ball.

Note: The DPE feature and the double block-and-bleed feature are not to be confused with one another.

The initial seal, at extremely low pressure differential or vacuum conditions, is obtained with spring-loaded floating seats, which are free to move slightly along the longitudinal axis of the valve. Line pressure behind the seat ring supplements the seat spring load to force the seat tightly against the ball.

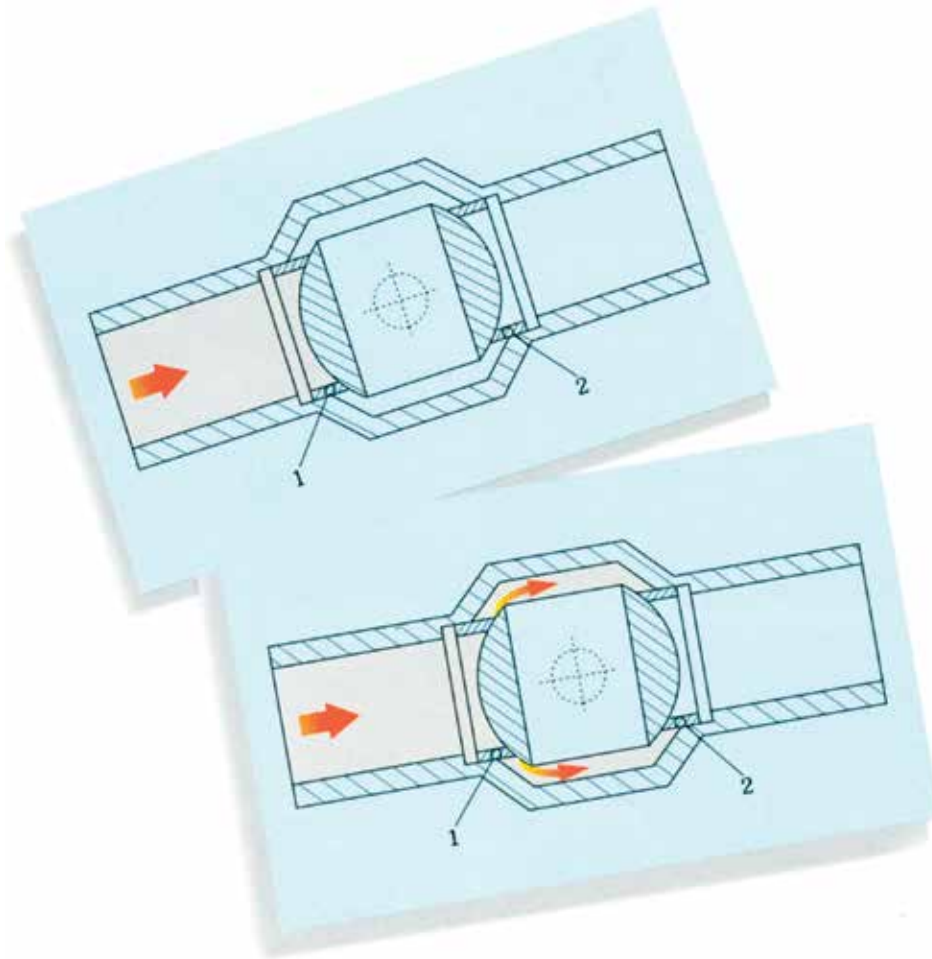

VALVE ASSEMBLY AND CROSS SECTION

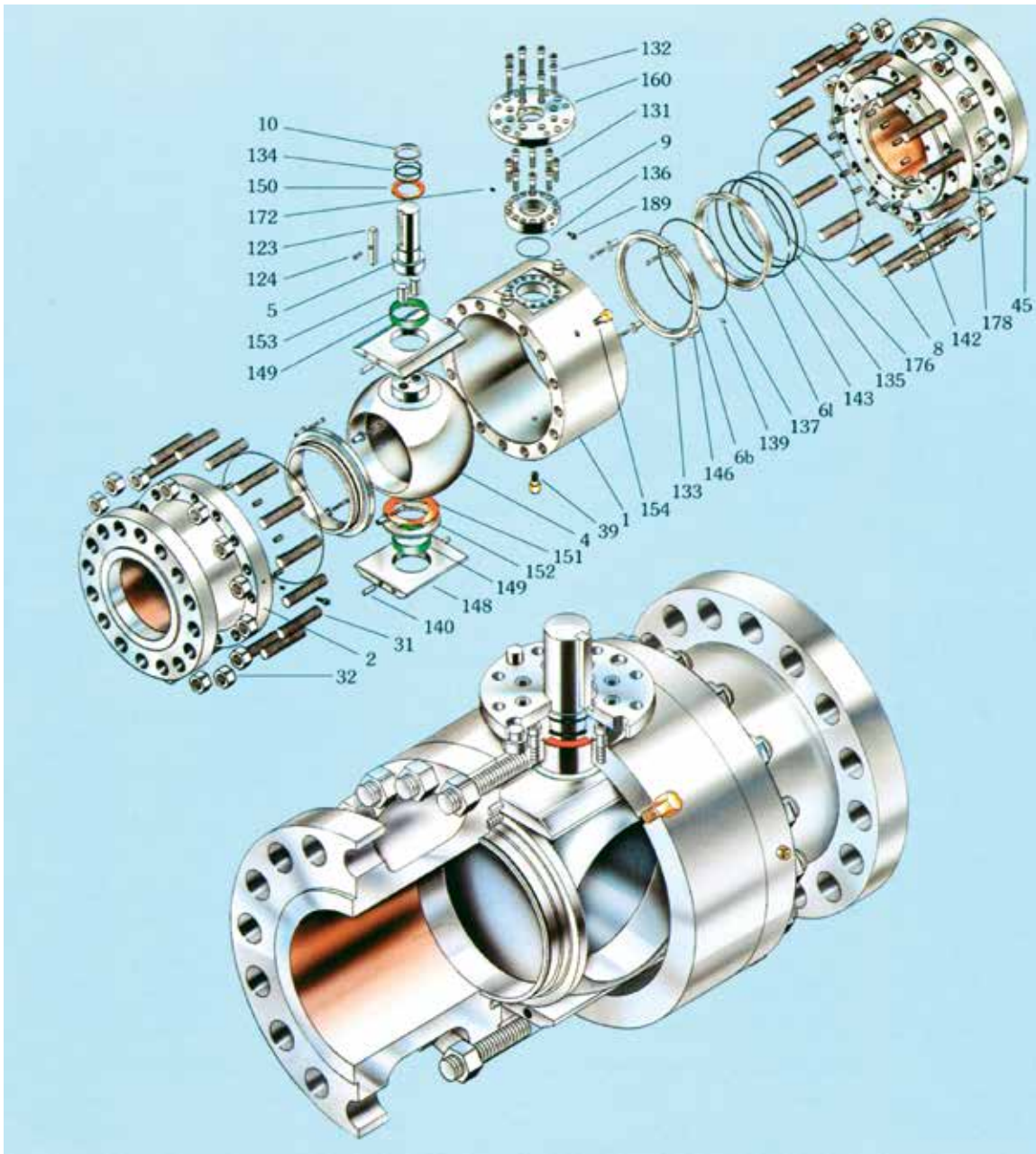

Item	Description	Item	Description	Item	Description
1	Body	45	Grease Fitting	146	Puller Bushing
2	Closure	123	Stem Key	148	Bearing Retainer
4	Ball	124	Stem Key Capscrew	149	Bearing
5	Stem	131	Gland Plate Capscrew	150	Upper Thrust Washer
6b	Outer Seat Ring	132	Adapter Plate Capscrew	151	Lower Thrust Washer
6l	Inner Seat Ring	134	Stem O-ring	152	Spacer
8	Body O-ring	135	Seat O-ring	153	Drive Pin
9	Gland Plate	136	Gland Plate O-ring	154	Relief Valve
10	Gland Bushing	137	Seal O-ring	160	Adapter Plate
31	Body Stud	139	Seat Spring Pin	172	Vent Plug
32	Body Stud Nut	140	Bearing Retainer Pin	176	U-cup Packing
39	Drain Valve	142	Spring	178	Check Valve
		143	Seat Lock Ring	189	Gland Vent

DIMENSIONS AND WEIGHTS

ASME CLASS 150

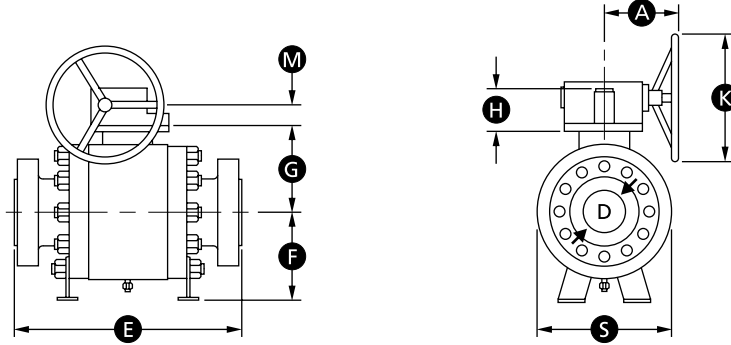

ASME CLASS 150

SIZE	in. (mm)	D	E			F	G	S	H	L	A	K	M	WEIGHT	
			WE	RF	RTJ									WE	RF/RTJ
6	6	6	18	15-1/2	16	11-7/8	8-1/2	11-7/8	2-3/4	-	8-3/4	13-3/4	2-5/8	440	520
(150)	(152)	(152)	(457)	(394)	(406)	(302)	(108)	(302)	(70)	-	(222)	(349)	(67)	(200)	(236)
8	8	8	20-1/2	18	18-1/2	13-3/8	9-7/8	15-5/8	2-3/4	-	8-3/4	13-3/4	2-5/8	720	850
(200)	(203)	(203)	(521)	(457)	(470)	(340)	(108)	(397)	(70)	-	(222)	(349)	(67)	(327)	(386)
10	10	10	22	21	21-1/2	14-7/8	11-5/8	18-1/4	2-3/4	-	8-3/4	13-3/4	2-5/8	1050	1250
(250)	(254)	(254)	(559)	(533)	(546)	(378)	(118)	(464)	(70)	-	(222)	(349)	(67)	(476)	(567)
12	12	12	25	24	24-1/2	16-3/8	13-1/2	21-5/8	2-3/4	-	8-3/4	13-3/4	2-5/8	1450	1740
(300)	(305)	(305)	(635)	(610)	(622)	(416)	(118)	(549)	(70)	-	(222)	(349)	(67)	(658)	(789)
14	13-1/4	13-1/4	30	27	27-1/2	18-3/8	14-5/8	23	3-3/4	-	11-1/2	13-3/4	3	1800	2160
(350)	(337)	(337)	(762)	(686)	(699)	(467)	(143)	(584)	(95)	-	(292)	(349)	(76)	(816)	(980)
16	15-1/4	15-1/4	33	30	30-1/2	19-7/8	16-1/4	26-3/8	3-3/4	-	11-1/2	13-3/4	3	2160	2570
(400)	(387)	(387)	(838)	(762)	(775)	(505)	(143)	(670)	(95)	-	(292)	(349)	(76)	(980)	(1166)
18	17-1/4	17-1/4	36	34	34-1/2	21-1/2	18	29-7/8	4-1/2	-	11-1/2	13-3/4	3	3020	3610
(450)	(438)	(438)	(914)	(864)	(876)	(546)	(168)	(759)	(114)	-	(292)	(349)	(76)	(1370)	(1637)
20	19-1/4	19-1/4	39	36	36-1/2	23-1/8	19-3/8	32-7/8	4-1/2	-	11-1/2	13-3/4	3	4050	4850
(500)	(489)	(489)	(991)	(914)	(927)	(587)	(168)	(835)	(114)	-	(292)	(349)	(76)	(1837)	(2200)
22	21-1/4	21-1/4	(1)	(1)	(1)	24-7/8	21-1/8	36-1/4	4-1/2	-	15-3/4	23-5/8	4-3/8	5020	6010
(550)	(540)	(540)				(632)	(537)	(921)	(114)	-	(400)	(600)	(111)	(2277)	(2726)
24	23-1/4	23-1/4	45	42	42-1/2	26-3/8	22-1/2	38-7/8	7-1/8	-	21-5/8	31-1/2	4-3/8	6010	7200
(600)	(591)	(591)	(1143)	(1067)	(1080)	(670)	(572)	(988)	(181)	-	(549)	(800)	(111)	(2726)	(3266)
26	25	25	49	45	(1)	28-1/4	24-1/2	41-3/4	7-1/8	-	21-5/8	31-1/2	4-3/8	7600	9120
(650)	(635)	(635)	(1245)	(1143)	(1)	(718)	(622)	(1060)	(181)	-	(549)	(800)	(111)	(3447)	(4137)
28	27	27	53	49	(1)	29-5/8	25-7/8	44-3/4	7-1/8	-	21-5/8	31-1/2	4-3/8	8700	10440
(700)	(686)	(686)	(1346)	(1245)	(1)	(753)	(657)	(1137)	(181)	-	(549)	(800)	(111)	(3946)	(4736)
30	29	29	55	51	(1)	31-3/4	27-1/2	48-5/8	7-1/8	-	21-5/8	31-1/2	4-3/8	10,420	12,500
(750)	(737)	(737)	(1397)	(1295)	(1)	(806)	(699)	(1235)	(181)	-	(549)	(800)	(111)	(4726)	(5670)
32	30-3/4	30-3/4	60	54	(1)	33-1/4	29	51	8-1/8	-	21-5/8	23-5/8	5-3/8	11,860	14,210
(800)	(781)	(781)	(1524)	(1372)	(1)	(845)	(737)	(1295)	(206)	-	(549)	(600)	(137)	(5380)	(6446)
34	32-3/4	32-3/4	64	58	(1)	34-3/8	30-7/8	53-3/8	8-1/8	-	21-3/4	23-5/8	5-3/8	14,500	17,390
(850)	(832)	(832)	(1626)	(1473)	(1)	(873)	(784)	(1356)	(206)	-	(552)	(600)	(137)	(6577)	(7888)
36	34-1/2	34-1/2	68	60	(1)	35-3/4	32-3/8	56-3/4	8-1/8	-	21-3/4	23-5/8	5-3/8	16,880	20,260
(900)	(876)	(876)	(1727)	(1524)	(1)	(908)	(822)	(1441)	(206)	-	(552)	(600)	(137)	(7657)	(9190)
40	38-1/2	38-1/2	(1)	(1)	(1)	39-3/8	35-5/8	63-7/8	8-1/8	-	21-3/4	23-5/8	5-3/8	21,560	25,850
(1000)	(978)	(978)				(1000)	(905)	(1623)	(206)	-	(552)	(600)	(137)	(9779)	(11,725)
42	40-1/4	40-1/4	(1)	(1)	(1)	40-3/4	38-1/8	67-3/8	8-1/8	-	21-3/4	23-5/8	5-3/8	25,390	30,460
(1050)	(1022)	(1022)				(1035)	(968)	(1711)	(206)	-	(552)	(600)	(137)	(11,517)	(13,816)
46	44	44	(1)	(1)	(1)	44-5/8	42-1/2	74-1/2	8-1/8	-	22-7/8	23-5/8	6-1/4	30,860	37030
(1150)	(1118)	(1118)				(1134)	(1080)	(1892)	(206)	-	(581)	(600)	(159)	(13,998)	(16,797)
48	46	46	(1)	(1)	(1)	46-3/8	44-3/8	77-1/2	8-1/8	-	22-7/8	23-5/8	6-1/4	35270	42320
(1200)	(1168)	(1168)				(1178)	(1127)	(1969)	(206)	-	(581)	(600)	(159)	(15,998)	(19,196)
56	54-1/2	54-1/2	(1)	(1)	(1)	52-3/4	50-3/8	89-3/4	9-5/8	-	-	-	-	54010	64810
(1400)	(1384)	(1384)				(1321)	(1280)	(2280)	(245)	-	-	-	-	(24,499)	(29,397)
60	57-1/2	57-1/2	(1)	(1)	(1)	56-3/8	55-1/8	96-3/8	9-5/8	-	-	-	-	66130	79,360
(1500)	(1461)	(1461)				(1432)	(1400)	(2448)	(245)	-	-	-	-	(29,996)	(35,997)

(1) Upon request

Shaded bore sizes (D) according to API 6D
Shaded end-to-end dimensions (E) according to API 6D

Larger sizes available on request
Reduced-bore valves also available

Flanges in accordance with ASME B16.5

Butt welding ends according to ASME B16.25

ASME CLASS 300

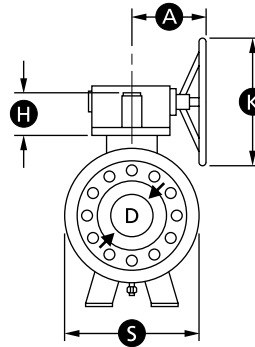
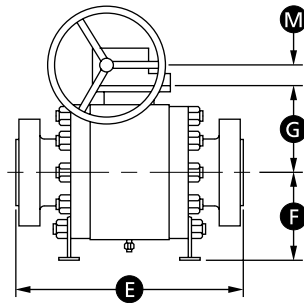

ASME CLASS 300

SIZE	in. (mm)	D	E			F	G	S	H	L	A	K	M	WEIGHT	
			WE	RF	RTJ									WE	RF/RTJ
6	6	6	18	15-7/8	16-1/2	11-7/8	8-1/2	12	2-3/4	-	8-3/4	13-3/4	2-5/8	460	550
(150)	(152)	(152)	(457)	(403)	(419)	(302)	(108)	(305)	(70)	-	(222)	(349)	(67)	(209)	(249)
8	8	8	20-1/2	19-3/4	20-3/8	13-3/8	9-7/8	15-7/8	2-3/4	-	8-3/4	13-3/4	2-5/8	740	880
(200)	(203)	(203)	(521)	(502)	(518)	(340)	(108)	(403)	(70)	-	(222)	(349)	(67)	(336)	(399)
10	10	10	22	22-3/8	23	14-7/8	11-5/8	18-3/8	3-3/4	-	11-1/2	13-3/4	3	1100	1320
(250)	(254)	(254)	(559)	(568)	(584)	(378)	(118)	(467)	(95)	-	(292)	(349)	(76)	(499)	(599)
12	12	12	25	25-1/2	26-1/8	16-3/8	13-1/2	21-3/4	3-3/4	-	11-1/2	13-3/4	3	1520	1800
(300)	(305)	(305)	(635)	(648)	(664)	(416)	(118)	(552)	(95)	-	(222)	(349)	(67)	(689)	(816)
14	13-1/4	13-1/4	30	30	30-5/8	18-3/8	14-5/8	23-1/4	4-1/2	-	11-1/2	13-3/4	3	1890	2270
(350)	(337)	(337)	(762)	(762)	(778)	(467)	(143)	(591)	(114)	-	(292)	(349)	(76)	(857)	(1030)
16	15-1/4	15-1/4	33	33	33-5/8	19-7/8	16-1/4	26-3/4	4-1/2	-	11-1/2	13-3/4	3	2240	2680
(400)	(387)	(387)	(838)	(838)	(854)	(505)	(143)	(679)	(114)	-	(292)	(349)	(76)	(1016)	(1216)
18	17-1/4	17-1/4	36	36	36-5/8	21-1/2	18	30-1/4	4-1/2	-	15-3/4	23-5/8	4-3/8	3150	3760
(450)	(438)	(438)	(914)	(914)	(930)	(546)	(168)	(768)	(114)	-	(400)	(600)	(111)	(1429)	(1706)
20	19-1/4	19-1/4	39	39	39-3/4	23-1/8	16-7/8	33-1/4	7-1/8	-	21-5/8	31-1/2	4-3/8	4250	5090
(500)	(489)	(489)	(991)	(991)	(1010)	(587)	(429)	(845)	(181)	-	(549)	(800)	(111)	(1928)	(2309)
22	21-1/4	21-1/4	43	43	43-7/8	24-7/8	21-1/8	36-5/8	7-1/8	-	21-5/8	31-1/2	4-3/8	5260	6300
(550)	(540)	(540)	(1092)	(1092)	(1115)	(632)	(537)	(930)	(181)	-	(549)	(800)	(111)	(2386)	(2858)
24	23-1/4	23-1/4	45	45	45-7/8	26-3/8	22-1/2	39-1/4	7-1/8	-	21-5/8	31-1/2	4-3/8	6300	7560
(600)	(591)	(591)	(1143)	(1143)	(1165)	(670)	(572)	(997)	(181)	-	(549)	(800)	(111)	(2858)	(3429)
26	25	25	49	49	50	28-1/4	24-1/2	42-1/8	8-1/8	-	21-3/4	23-5/8	5-3/8	7980	9560
(650)	(635)	(635)	(1245)	(1245)	(1270)	(718)	(622)	(1070)	(206)	-	(552)	(600)	(137)	(3620)	(4336)
28	27	27	53	53	54	29-5/8	25-7/8	45-1/4	8-1/8	-	21-3/4	23-5/8	5-3/8	9120	10,930
(700)	(686)	(686)	(1346)	(1346)	(1372)	(753)	(657)	(1149)	(206)	-	(552)	(600)	(137)	(4137)	(4958)
30	29	29	55	55	56	31-3/4	27-1/2	49-1/8	8-1/8	-	21-3/4	23-5/8	5-3/8	10,930	13,110
(750)	(737)	(737)	(1397)	(1397)	(1422)	(806)	(699)	(1248)	(206)	-	(552)	(600)	(137)	(4958)	(5947)
32	30-3/4	30-3/4	60	60	61-1/8	33-1/4	29	51-1/2	8-1/8	-	21-3/4	23-5/8	5-3/8	12,430	14,900
(800)	(781)	(781)	(1524)	(1524)	(1553)	(845)	(737)	(1308)	(206)	-	(552)	(600)	(137)	(5638)	(6759)
34	32-3/4	32-3/4	64	64	65-1/8	34-3/8	30-7/8	53-7/8	8-1/8	-	21-3/4	23-5/8	5-3/8	15,210	18,250
(850)	(832)	(832)	(1626)	(1626)	(1654)	(873)	(784)	(1369)	(206)	-	(552)	(600)	(137)	(6899)	(8278)
36	34-1/2	34-1/2	68	68	69-1/8	35-3/4	32-3/8	57-3/8	8-1/8	-	22-7/8	23-5/8	6-1/4	17,720	21,250
(900)	(876)	(876)	(1727)	(1727)	(1756)	(908)	(822)	(1457)	(206)	-	(581)	(600)	(159)	(8038)	(9639)
40	38-1/2	38-1/2	(1)	(1)	(1)	39-3/8	35-5/8	64-1/2	8-1/8	-	22-7/8	23-5/8	6-1/4	22,610	27,130
(1000)	(978)	(978)	(1)	(1)	(1)	(1000)	(905)	(1638)	(206)	-	(581)	(600)	(159)	(10,256)	(12,306)
42	40-1/4	40-1/4	(1)	(1)	(1)	40-3/4	38-1/8	68-1/8	9-5/8	-	22-7/8	23-5/8	6-1/4	26,650	31,960
(1050)	(1022)	(1022)	(1)	(1)	(1)	(1035)	(968)	(1730)	(245)	-	(581)	(600)	(159)	(12,088)	(14,497)
46	44	44	(1)	(1)	(1)	44-5/8	42-1/2	75-1/4	9-5/8	-	22-7/8	23-5/8	6-1/4	32,400	38,880
(1150)	(1118)	(1118)	(1)	(1)	(1)	(1134)	(1080)	(1911)	(245)	-	(581)	(600)	(159)	(14,696)	(17,636)
48	46	46	(1)	(1)	(1)	46-3/8	44-3/8	78-1/4	9-5/8	-	25-5/8	47-1/4	6-5/8	37,030	44,440
(1200)	(1168)	(1168)	(1)	(1)	(1)	(1178)	(1127)	(1988)	(245)	-	(651)	(1200)	(168)	(16,797)	(20,158)
56	54-1/2	54-1/2	(1)	(1)	(1)	52-3/4	50-3/8	90-3/4	9-5/8	-	-	-	-	56,700	68,030
(1400)	(1384)	(1384)	(1)	(1)	(1)	(1321)	(1280)	(2305)	(245)	-	-	-	-	(25,719)	(30,858)
60	57-1/2	57-1/2	(1)	(1)	(1)	56-3/8	55-1/8	97-1/2	9-5/8	-	-	-	-	69,440	83,330
(1500)	(1461)	(1461)	(1)	(1)	(1)	(1432)	(1400)	(2477)	(245)	-	-	-	-	(31,497)	(37,798)

(1) Upon request

Shaded bore sizes (D) according to API 6D
 Shaded end-to-end dimensions (E) according to API 6D
 Butt welding ends according to ASME B16.25

Flanges in accordance with ASME B16.5

DIMENSIONS AND WEIGHTS (CONT.)

ASME CLASS 400

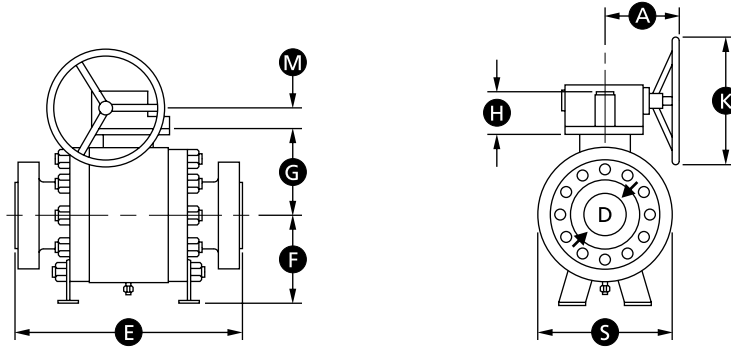

ASME CLASS 400

SIZE	in. (mm)	D	E			F	G	S	H	L	A	K	M	WEIGHT	
			WE	RF	RTJ									WE	RF/RTJ
6	6	6	19-1/2	19-1/2	19-5/8	12-1/8	8-1/2	12-1/8	2-3/4	-	8-3/4	13-3/4	2-5/8	520	610
(150)	(152)	(152)	(495)	(495)	(499)	(308)	(108)	(308)	(70)	-	(222)	(349)	(67)	(236)	(277)
8	8	8	23-1/2	23-1/2	23-5/8	13-5/8	9-7/8	16	3-3/4	-	11-1/2	13-3/4	3	850	1010
(200)	(203)	(203)	(597)	(597)	(600)	(346)	(108)	(406)	(95)	-	(292)	(349)	(76)	(386)	(458)
10	10	10	26-1/2	26-1/2	26-5/8	15-1/4	11-5/8	18-5/8	3-3/4	-	11-1/2	13-3/4	3	1250	1490
(250)	(254)	(254)	(673)	(673)	(676)	(387)	(118)	(473)	(95)	-	(292)	(349)	(76)	(567)	(676)
12	12	12	30	30	30-1/8	16-3/4	13-1/2	22	3-3/4	-	11-1/2	13-3/4	3	1740	2070
(300)	(305)	(305)	(762)	(762)	(765)	(425)	(118)	(559)	(95)	-	(292)	(349)	(67)	(789)	(939)
14	13-1/4	13-1/4	32-1/2	32-1/2	32-5/8	18-3/4	14-5/8	23-1/2	4-1/2	-	11-1/2	13-3/4	3	2160	2570
(350)	(337)	(337)	(826)	(826)	(829)	(476)	(143)	(597)	(114)	-	(292)	(349)	(76)	(980)	(1166)
16	15-1/4	15-1/4	35-1/2	35-1/2	35-5/8	20-3/8	16-1/4	27	4-1/2	-	11-1/2	13-3/4	3	2570	3080
(400)	(387)	(387)	(902)	(902)	(905)	(518)	(143)	(686)	(114)	-	(292)	(349)	(76)	(1166)	(1397)
18	17-1/4	17-1/4	38-1/2	38-1/2	38-5/8	21-7/8	18	30-1/2	7-1/8	-	21-5/8	31-1/2	4-3/8	3610	4320
(450)	(438)	(438)	(978)	(978)	(981)	(556)	(168)	(775)	(181)	-	(549)	(800)	(111)	(1637)	(1960)
20	19-1/4	19-1/4	41-1/2	41-1/2	41-3/4	23-1/2	19-3/8	33-1/2	7-1/8	-	21-5/8	31-1/2	4-3/8	4870	5840
(500)	(489)	(489)	(1054)	(1054)	(1056)	(597)	(492)	(851)	(181)	-	(549)	(800)	(111)	(2209)	(2649)
22	21-1/4	21-1/4	45	45	45-3/8	25-3/8	21-1/8	37	7-1/8	-	21-5/8	31-1/2	4-3/8	6040	7230
(550)	(540)	(540)	(1143)	(1143)	(1153)	(645)	(537)	(940)	(181)	-	(549)	(800)	(111)	(2740)	(3279)
24	23-1/4	23-1/4	48-1/2	48-1/2	48-7/8	26-7/8	22-1/2	39-5/8	8-1/8	-	21-3/4	23-5/8	5-3/8	7230	8660
(600)	(591)	(591)	(1232)	(1232)	(1242)	(683)	(572)	(1007)	(206)	-	(552)	(600)	(137)	(3279)	(3928)
26	25	25	51-1/2	51-1/2	51	28-7/8	24-1/2	42-1/2	8-1/8	-	21-3/4	23-5/8	5-3/8	9170	11,000
(650)	(635)	(635)	(1308)	(1308)	(1295)	(734)	(622)	(1080)	(206)	-	(552)	(600)	(137)	(4159)	(4990)
28	27	27	55	55	55-1/2	30-1/4	25-7/8	45-5/8	8-1/8	-	21-3/4	23-5/8	5-3/8	10,490	12,580
(700)	(686)	(686)	(1397)	(1397)	(1410)	(768)	(657)	(1159)	(206)	-	(552)	(600)	(137)	(4758)	(5706)
30	29	29	60	60	60-1/2	32-3/8	27-1/2	49-5/8	8-1/8	-	21-3/4	23-5/8	5-3/8	12,560	15,070
(750)	(737)	(737)	(1524)	(1524)	(1537)	(822)	(699)	(1261)	(206)	-	(552)	(600)	(137)	(5697)	(6836)
32	30-3/4	30-3/4	65	65	65-5/8	33-7/8	29	52	8-1/8	-	22-7/8	23-5/8	6-1/4	14,280	17,120
(800)	(781)	(781)	(1651)	(1651)	(1667)	(861)	(737)	(1321)	(206)	-	(581)	(600)	(159)	(6477)	(7766)
34	32-3/4	32-3/4	70	70	70-5/8	35-1/8	30-7/8	54-1/2	8-1/8	-	22-7/8	23-5/8	6-1/4	17,480	20,960
(850)	(832)	(832)	(1778)	(1778)	(1794)	(892)	(784)	(1384)	(206)	-	(581)	(600)	(159)	(7929)	(9507)
36	34-1/2	34-1/2	74	74	74-5/8	36-1/2	32-3/8	58	8-1/8	-	22-7/8	23-5/8	6-1/4	20,370	24,420
(900)	(876)	(876)	(1880)	(1880)	(1896)	(927)	(822)	(1473)	(206)	-	(581)	(600)	(159)	(9240)	(11,077)
40	38-1/2	38-1/2	(1)	(1)	(1)	40-1/8	35-5/8	65-1/8	9-5/8	-	22-7/8	23-5/8	6-1/4	25,990	31,170
(1000)	(978)	(978)	(1)	(1)	(1)	(1019)	(905)	(1654)	(245)	-	(581)	(600)	(159)	(11,789)	(14,138)
42	40-1/4	40-1/4	(1)	(1)	(1)	41-1/2	38-1/8	68-3/4	9-5/8	-	22-7/8	23-5/8	6-1/4	30,640	36,770
(1050)	(1022)	(1022)	(1)	(1)	(1)	(1054)	(968)	(1746)	(245)	-	(581)	(600)	(159)	(13,898)	(16,679)
46	44	44	(1)	(1)	(1)	45-5/8	42-1/2	76	9-5/8	-	22-7/8	23-5/8	6-1/4	37,250	44,700
(1150)	(1118)	(1118)	(1)	(1)	(1)	(1159)	(1080)	(2007)	(245)	-	(581)	(600)	(159)	(16,896)	(20,276)
48	46	46	(1)	(1)	(1)	47-3/8	44-3/8	79	9-5/8	-	25-5/8	47-1/4	6-5/8	42,590	51,100
(1200)	(1168)	(1168)	(1)	(1)	(1)	(1203)	(1127)	(1988)	(245)	-	(651)	(1200)	(168)	(19,319)	(23,179)
56	54-1/2	54-1/2	(1)	(1)	(1)	53-3/4	50-3/8	91-5/8	11	-	-	-	-	65,180	78,210
(1400)	(1384)	(1384)	(1)	(1)	(1)	(1365)	(1280)	(2327)	(279)	-	-	-	-	(29,565)	(35,475)
60	57-1/2	57-1/2	(1)	(1)	(1)	57-1/2	55-1/8	98-3/8	11	-	-	-	-	79,850	95,810
(1500)	(1461)	(1461)	(1)	(1)	(1)	(1461)	(1400)	(2499)	(279)	-	-	-	-	(36,219)	(43,459)

(1) Upon request

Shaded bore sizes (D) according to API 6D
Shaded end-to-end dimensions (E) according to API 6D

Flanges in accordance with ASME B16.5

Butt welding ends according to ASME B16.25

ASME CLASS 600

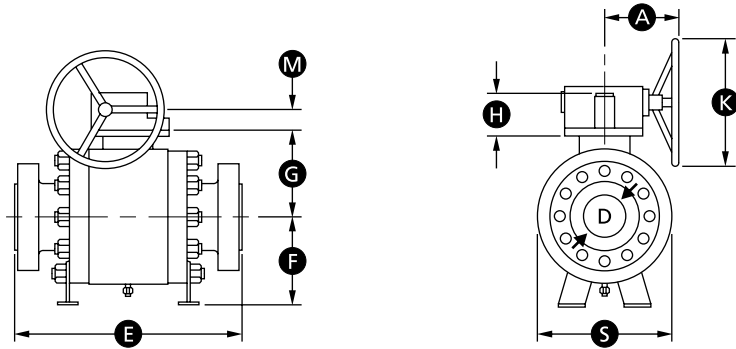

ASME CLASS 600

SIZE	in. (mm)	D	E			F	G	S	H	L	A	K	M	WEIGHT	
			WE	RF	RTJ									WE	RF/RTJ
6	6	6	22	22	22-1/8	12-1/4	8-1/2	12-1/4	2-3/4	-	8-3/4	13-3/4	2-5/8	570	680
(150)	(152)	(152)	(559)	(559)	(562)	(311)	(108)	(311)	(70)	-	(222)	(349)	(67)	(259)	(308)
8	8	8	26	26	26-1/8	13-3/4	9-7/8	16-1/8	3-3/4	-	11-1/2	13-3/4	3	920	1100
(200)	(203)	(203)	(660)	(660)	(664)	(349)	(108)	(410)	(95)	-	(292)	(349)	(76)	(417)	(500)
10	10	10	31	31	31-1/8	15-3/8	11-5/8	18-7/8	3-3/4	-	11-1/2	13-3/4	3	1360	1630
(250)	(254)	(254)	(787)	(787)	(790)	(391)	(118)	(480)	(95)	-	(292)	(349)	(76)	(617)	(739)
12	12	12	33	33	33-1/8	16-7/8	13-1/2	22-1/4	3-3/4	-	11-1/2	13-3/4	3	1890	2270
(300)	(305)	(305)	(838)	(838)	(841)	(429)	(118)	(565)	(95)	-	(292)	(349)	(67)	(857)	(1030)
14	13-1/4	13-1/4	35	35	35-1/8	18-7/8	14-5/8	23-3/4	4-1/2	-	11-1/2	13-3/4	3	2330	2790
(350)	(337)	(337)	(889)	(889)	(892)	(480)	(143)	(603)	(114)	-	(292)	(349)	(76)	(1057)	(1266)
16	15-1/4	15-1/4	39	39	39-1/8	20-1/2	16-1/4	27-1/4	4-1/2	-	15-3/4	23-5/8	4-3/8	2790	3350
(400)	(387)	(387)	(991)	(991)	(994)	(521)	(143)	(692)	(114)	-	(400)	(600)	(111)	(1266)	(1520)
18	17-1/4	17-1/4	43	43	43-1/8	22-1/8	18	30-7/8	7-1/8	-	21-5/8	31-1/2	4-3/8	3920	4690
(450)	(438)	(438)	(1092)	(1092)	(1095)	(562)	(168)	(784)	(181)	-	(549)	(800)	(111)	(1778)	(2127)
20	19-1/4	19-1/4	47	47	47-1/4	23-3/4	19-3/8	33-7/8	7-1/8	-	21-5/8	31-1/2	4-3/8	5290	6340
(500)	(489)	(489)	(1194)	(1194)	(1200)	(603)	(492)	(861)	(181)	-	(549)	(800)	(111)	(2400)	(2876)
22	21-1/4	21-1/4	51	51	51-3/8	25-5/8	21-1/8	37-3/8	8-1/8	-	21-5/8	23-5/8	5-3/8	6560	7870
(550)	(540)	(540)	(1295)	(1295)	(1305)	(651)	(537)	(949)	(206)	-	(549)	(600)	(137)	(2976)	(3570)
24	23-1/4	23-1/4	55	55	55-3/8	27-1/8	22-1/2	40-1/8	8-1/8	-	21-3/4	23-5/8	5-3/8	7870	9430
(600)	(591)	(591)	(1397)	(1397)	(1407)	(689)	(572)	(1019)	(206)	-	(552)	(600)	(137)	(3570)	(4277)
26	25	25	57	57	57-1/2	29-1/8	24-1/2	43	8-1/8	-	22-7/8	23-5/8	6-1/4	9980	11,970
(650)	(635)	(635)	(1448)	(1448)	(1461)	(740)	(622)	(1092)	(206)	-	(581)	(600)	(159)	(4527)	(5430)
28	27	27	61	61	61-1/2	30-1/2	25-7/8	46-1/8	8-1/8	-	22-7/8	23-5/8	6-1/4	11,410	13,690
(700)	(686)	(686)	(1549)	(1549)	(1562)	(775)	(657)	(1172)	(206)	-	(581)	(600)	(159)	(5175)	(6210)
30	29	29	65	65	65-1/2	32-5/8	27-1/2	50-1/8	9-5/8	-	22-7/8	23-5/8	6-1/4	13,690	16,420
(750)	(737)	(737)	(1651)	(1651)	(1664)	(829)	(699)	(1273)	(245)	-	(581)	(600)	(159)	(6210)	(7448)
32	30-3/4	30-3/4	70	70	70-5/8	34-1/4	29	52-1/2	9-5/8	-	22-7/8	23-5/8	6-1/4	15,560	18,670
(800)	(781)	(781)	(1778)	(1778)	(1794)	(870)	(737)	(1334)	(245)	-	(581)	(600)	(159)	(7058)	(8469)
34	32-3/4	32-3/4	76	76	76-5/8	35-3/8	30-7/8	55	9-5/8	-	22-7/8	23-5/8	6-1/4	19,040	22,830
(850)	(832)	(832)	(1930)	(1930)	(1946)	(899)	(784)	(1397)	(245)	-	(581)	(600)	(159)	(8636)	(10,356)
36	34-1/2	34-1/2	82	82	82-5/8	36-7/8	32-3/8	58-1/2	9-5/8	-	22-7/8	23-5/8	6-1/4	22,200	26,630
(900)	(876)	(876)	(2083)	(2083)	(2099)	(937)	(822)	(1486)	(245)	-	(581)	(600)	(159)	(10,070)	(12,079)
40	38-1/2	38-1/2	(1)	(1)	(1)	40-1/2	35-5/8	65-7/8	9-5/8	-	22-7/8	23-5/8	6-1/4	28,320	33,990
(1000)	(978)	(978)	(1)	(1)	(1)	(1029)	(905)	(1673)	(245)	-	(581)	(600)	(159)	(12,846)	(15,418)
42	40-1/4	40-1/4	(1)	(1)	(1)	42	38-1/8	69-1/2	9-5/8	-	25-5/8	47-1/4	6-5/8	33,390	40,070
(1050)	(1022)	(1022)	(1)	(1)	(1)	(1067)	(968)	(1765)	(245)	-	(651)	(1200)	(168)	(15,145)	(18,175)
46	44	44	(1)	(1)	(1)	46-1/8	42-1/2	76-3/4	9-5/8	-	25-5/8	47-1/4	6-5/8	40,600	48,720
(1150)	(1118)	(1118)	(1)	(1)	(1)	(1171)	(1080)	(1949)	(245)	-	(651)	(1200)	(168)	(18,416)	(22,099)
48	46	46	85-7/8	85-7/8	(1)	47-7/8	44-3/8	79-7/8	9-5/8	-	25-5/8	47-1/4	6-5/8	46,400	55,680
(1200)	(1168)	(1168)	(2181)	(2181)	(1)	(1216)	(1127)	(2029)	(245)	-	(651)	(1200)	(168)	(21,047)	(25,256)
56	54-1/2	54-1/2	(1)	(1)	(1)	54-3/8	50-3/8	92-5/8	11	-	-	-	-	71,050	85,250
(1400)	(1384)	(1384)	(1)	(1)	(1)	(1381)	(1280)	(2353)	(279)	-	-	-	-	(32,228)	(38,669)
60	57-1/2	57-1/2	(1)	(1)	(1)	58-1/8	55-1/8	99-3/8	11	-	-	-	-	87,010	104,400
(1500)	(1461)	(1461)	(1)	(1)	(1)	(1476)	(1400)	(2524)	(279)	-	-	-	-	(39,467)	(47,355)

(1) Upon request

Shaded bore sizes (D) according to API 6D
 Shaded end-to-end dimensions (E) according to API 6D
 Butt welding ends according to ASME B16.25

Flanges in accordance with ASME B16.5

DIMENSIONS AND WEIGHTS (CONT.)

ASME CLASS 900

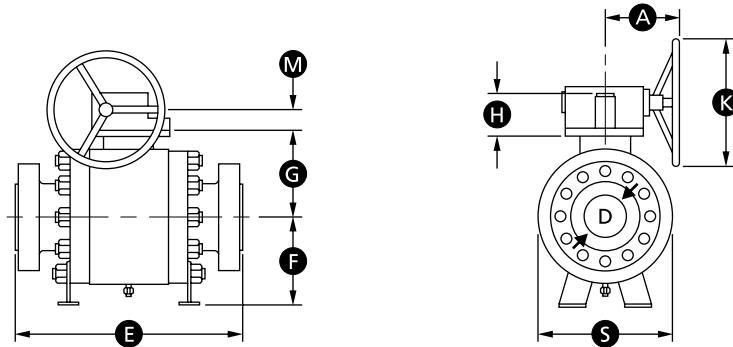

ASME CLASS 900

SIZE	in.	D	E			F	G	S	H	L	A	K	M	WEIGHT	
			WE	RF	RTJ									WE	RF/RTJ
6	6	6	24	24	24-1/8	9-7/8	9-1/2	13-1/4	3-3/4	-	11-1/2	13-3/4	3	720	850
(150)	(152)	(152)	(610)	(610)	(613)	(251)	(241)	(337)	(95)	-	(292)	(349)	(76)	(327)	(386)
8	8	8	29	29	29-1/8	11-3/8	10-7/8	16-1/2	3-3/4	-	11-1/2	13-3/4	3	1190	1410
(200)	(203)	(203)	(737)	(737)	(740)	(289)	(276)	(419)	(95)	-	(292)	(349)	(76)	(540)	(640)
10	10	10	33	33	33-1/8	13-5/8	12-1/2	20-1/8	4-1/2	-	11-1/2	13-3/4	3	1760	2110
(250)	(254)	(254)	(838)	(838)	(841)	(346)	(318)	(511)	(114)	-	(292)	(349)	(76)	(798)	(957)
12	12	12	38	38	38-1/8	15-3/8	14-3/8	23-5/8	4-1/2	-	11-1/2	13-3/4	3	2440	2930
(300)	(305)	(305)	(965)	(965)	(968)	(391)	(365)	(600)	(114)	-	(292)	(349)	(67)	(1107)	(1329)
14	12-3/4	40-1/2	40-1/2	40-1/2	40-7/8	17-3/4	15-3/8	26-3/4	4-1/2	-	15-3/4	23-5/8	4-3/8	3020	3610
(350)	(324)	(1029)	(1029)	(1029)	(1038)	(451)	(391)	(679)	(114)	-	(400)	(600)	(111)	(1370)	(1637)
16	14-3/4	44-1/2	44-1/2	44-1/2	44-7/8	19-5/8	16-7/8	30-3/8	7-1/8	-	21-5/8	31-1/2	4-3/8	3630	4360
(400)	(375)	(1130)	(1130)	(1130)	(1140)	(499)	(429)	(772)	(181)	-	(549)	(800)	(111)	(1647)	(1978)
18	16-3/4	48	48	48	48-1/2	21-5/8	19-1/8	33-1/2	7-1/8	-	21-5/8	31-1/2	5-3/8	5090	6100
(450)	(425)	(1219)	(1219)	(1219)	(1232)	(549)	(486)	(851)	(181)	-	(549)	(800)	(137)	(2309)	(2767)
20	18-5/8	52	52	52-1/2	23-1/4	20-7/8	36-1/4	8-1/8	-	-	21-3/4	23-5/8	6-1/4	6870	8240
(500)	(473)	(1321)	(1321)	(1334)	(591)	(530)	(921)	(206)	-	-	(552)	(600)	(159)	(3116)	(3738)
22	20-5/8	(1)	(1)	(1)	25-3/4	21-7/8	40-1/2	8-1/8	-	-	22-7/8	23-5/8	6-1/4	8530	10,220
(550)	(524)	(1)	(1)	(1)	(654)	(556)	(1029)	(206)	-	-	(581)	(600)	(159)	(3869)	(4636)
24	22-1/2	61	61	61-3/4	27-1/2	24-3/8	43-3/4	9-5/8	-	-	22-7/8	23-5/8	6-1/4	10,220	12,250
(600)	(572)	(1549)	(1549)	(1568)	(699)	(619)	(1111)	(245)	-	-	(581)	(600)	(159)	(4636)	(5557)
26	24-3/8	(1)	(1)	(1)	29-7/8	26-1/4	47-1/4	9-5/8	-	-	22-7/8	23-5/8	6-1/4	12,960	15,540
(650)	(619)	(1)	(1)	(1)	(759)	(667)	(1200)	(245)	-	-	(581)	(600)	(159)	(5879)	(7049)
28	26-1/4	(1)	(1)	(1)	31-7/8	27-7/8	50-3/4	9-5/8	-	-	22-7/8	23-5/8	6-1/4	14,830	17,790
(700)	(667)	(1)	(1)	(1)	(810)	(708)	(1289)	(245)	-	-	(581)	(600)	(159)	(6727)	(8069)
30	28-1/8	(1)	(1)	(1)	32-3/4	29-5/8	53-3/8	9-5/8	-	-	22-7/8	23-5/8	6-1/4	17,790	21,340
(750)	(715)	(1)	(1)	(1)	(832)	(753)	(1356)	(245)	-	-	(581)	(600)	(159)	(8069)	(9680)
32	30	(1)	(1)	(1)	35-7/8	31-7/8	57-1/2	9-5/8	-	-	22-7/8	23-5/8	6-1/4	20,210	24,250
(800)	(762)	(1)	(1)	(1)	(911)	(810)	(1461)	(245)	-	-	(581)	(600)	(159)	(9167)	(11,000)
34	31-7/8	(1)	(1)	(1)	37-3/4	33-3/8	61	9-5/8	-	-	22-7/8	23-5/8	6-1/4	24,750	29,690
(850)	(810)	(1)	(1)	(1)	(959)	(848)	(1549)	(245)	-	-	(581)	(600)	(159)	(11,226)	(13,467)
36	33-3/4	(1)	(1)	(1)	40-1/8	34-3/4	64-3/8	11	-	-	22-7/8	23-5/8	6-1/4	28,850	34,610
(900)	(857)	(1)	(1)	(1)	(1019)	(883)	(1635)	(279)	-	-	(581)	(600)	(159)	(13,086)	(15,699)
40	37-5/8	(1)	(1)	(1)	44-1/8	38-1/4	71-1/4	11	-	-	22-7/8	23-5/8	6-1/4	36,810	44,170
(1000)	(956)	(1)	(1)	(1)	(1121)	(972)	(1810)	(279)	-	-	(581)	(600)	(159)	(16,697)	(20,035)
42	39-5/8	(1)	(1)	(1)	47-1/4	41-3/4	74-3/4	11	-	-	22-7/8	23-5/8	6-1/4	43,400	52,070
(1050)	(1007)	(1)	(1)	(1)	(1200)	(1060)	(1888)	(279)	-	-	(581)	(600)	(159)	(19,686)	(23,619)
46	43-3/8	(1)	(1)	(1)	50-3/8	43-3/4	81-1/2	11	-	-	22-7/8	23-5/8	6-1/4	52,770	63,310
(1150)	(1102)	(1)	(1)	(1)	(1280)	(1111)	(2070)	(279)	-	-	(581)	(600)	(159)	(23,936)	(28,717)
48	45-1/4	(1)	(1)	(1)	52-3/8	45-1/4	85	11	-	-	25-5/8	47-1/4	6-5/8	60,310	72,370
(1200)	(1149)	(1)	(1)	(1)	(1330)	(1149)	(2159)	(279)	-	-	(651)	(1200)	(168)	(27,356)	(32,826)

(1) Upon request

Shaded bore sizes (D) according to API 6D
 Shaded end-to-end dimensions (E) according to API 6D

Flanges in accordance with ASME B16.5

Butt welding ends according to ASME B16.25

ASME CLASS 1500

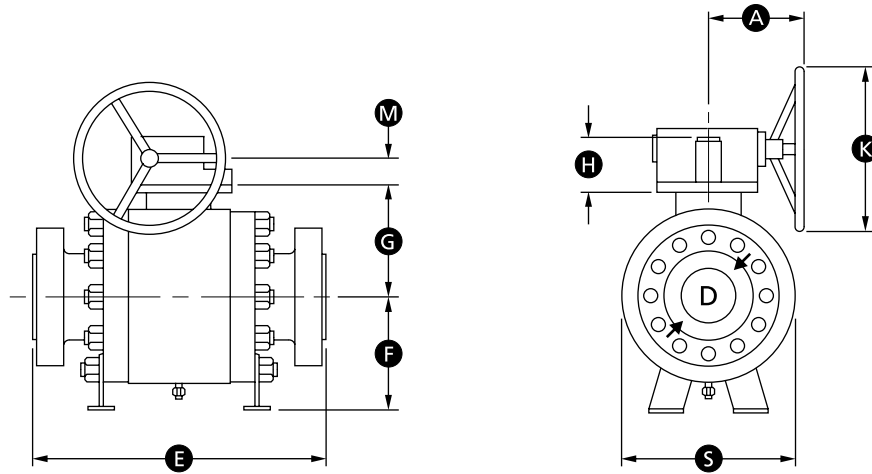

ASME CLASS 1500

SIZE	in. (mm)	D	E			F	G	S	H	L	A	K	M	WEIGHT	
			WE	RF	RTJ									WE	RF/RTJ
6	(150)	5-3/4 (146)	27-3/4 (705)	27-3/4 (705)	28 (711)	12-5/8 (321)	11 (279)	16-7/8 (429)	3-3/4 (95)	-	11-1/2 (292)	13-3/4 (349)	3 (76)	850 (386)	1010 (458)
8	(200)	7-5/8 (194)	32-3/4 (832)	32-3/4 (832)	33-1/8 (841)	14-5/8 (372)	12-7/8 (327)	21-1/8 (537)	4-1/2 (114)	-	11-1/2 (292)	13-3/4 (349)	3 (76)	1410 (640)	1670 (757)
10	(250)	9-1/2 (241)	39 (991)	39 (991)	39-3/8 (1000)	17-3/8 (441)	15-3/8 (391)	25-3/4 (654)	4-1/2 (114)	-	11-1/2 (292)	13-3/4 (349)	3 (76)	2110 (957)	2530 (1148)
12	(300)	11-3/8 (289)	44-1/2 (1130)	44-1/2 (1130)	45-1/8 (1146)	19-5/8 (499)	16-5/8 (422)	30-1/4 (768)	4-1/2 (114)	-	11-1/2 (292)	13-3/4 (349)	3 (67)	2930 (1329)	3500 (1610)
14	(350)	12-1/2 (318)	49-1/2 (1257)	49-1/2 (1257)	50-1/4 (1276)	22-5/8 (575)	19-5/8 (499)	34-1/4 (870)	7-1/8 (181)	-	15-3/4 (400)	23-5/8 (600)	4-3/8 (111)	3610 (1637)	4320 (1960)
16	(400)	14-1/4 (362)	54-1/2 (1384)	54-1/2 (1384)	55-3/8 (1407)	25-1/4 (641)	22 (559)	38-3/4 (984)	7-1/8 (181)	-	21-5/8 (549)	31-1/2 (800)	4-3/8 (111)	4360 (1978)	5220 (2368)
18	(450)	16-1/4 (413)	(1)	(1)	(1)	27-3/4 (705)	23-1/4 (591)	42-7/8 (1089)	8-1/8 (206)	-	21-5/8 (549)	31-1/2 (800)	4-3/8 (111)	6100 (2767)	7310 (3316)
20	(500)	18 (457)	(1)	(1)	(1)	29-7/8 (759)	28-1/2 (724)	46-3/8 (1178)	9-5/8 (245)	-	21-3/4 (552)	23-5/8 (600)	5-3/8 (137)	8240 (3738)	9870 (4477)
22	(550)	19-3/4 (502)	(1)	(1)	(1)	33 (838)	30-1/4 (768)	51-7/8 (1318)	9-5/8 (245)	-	22-7/8 (581)	23-5/8 (600)	6-1/4 (159)	10,220 (4636)	12,250 (5557)
24	(600)	21-5/8 (549)	(1)	(1)	(1)	35-1/8 (892)	32 (813)	55-7/8 (1419)	9-5/8 (245)	-	22-7/8 (581)	23-5/8 (600)	6-1/4 (159)	12,250 (5557)	14,700 (6668)
26	(650)	23-1/2 (597)	(1)	(1)	(1)	38-1/4 (972)	35-1/2 (902)	60-1/2 (1537)	11 (279)	-	-	-	-	15,540 (7049)	18,650 (8459)
28	(700)	25-1/4 (641)	(1)	(1)	(1)	40-7/8 (1038)	37 (940)	65 (1651)	11 (279)	-	-	-	-	17,790 (8069)	21,340 (9680)
30	(750)	27 (686)	(1)	(1)	(1)	42 (1067)	40-3/4 (1035)	68-3/8 (1737)	11 (279)	-	-	-	-	21,340 (9680)	25,590 (11,607)
32	(800)	28-3/4 (730)	(1)	(1)	(1)	45-7/8 (1165)	41-3/4 (1060)	73-5/8 (1870)	11 (279)	-	-	-	-	24,250 (11,000)	29,100 (31,200)
34	(850)	30-1/2 (775)	(1)	(1)	(1)	48-3/8 (1229)	44-7/8 (1137)	78-1/8 (1984)	11 (279)	-	-	-	-	29,690 (13,467)	35,620 (16,157)
36	(900)	32-1/4 (819)	(1)	(1)	(1)	51-3/8 (1305)	46-1/2 (1181)	82-3/8 (2092)	11 (279)	-	-	-	-	34,610 (15,699)	41,530 (18,838)

(1) Upon request

Shaded bore sizes (D) according to API 6D
 Shaded end-to-end dimensions (E) according to API 6D
 Butt welding ends according to ASME B16.25

Flanges in accordance with ASME B16.5

GROVE B7

DESIGN FEATURES

Standard Features

B7.1

- Triple-barrier stem seals
- Factory-positioned external stops
- Emergency grease fitting for stem
- Stem separated from the ball; anti-blowout design
- Plastic polymer insert for seat sealing
- Self-relieving seats
- Metal-backed, self-lubricating bearings/washers
- Nickel plating for trim parts
- Fire-safe graphite rings
- Antistatic device

B7.B

- Triple-barrier stem seals
- Stem separate from the ball; anti-blowout design
- Ball load on the bearing blocks
- Double-barrier sealing in both directions (DPE)
- Body relief valve for overpressure
- Sealant injection system for emergency seal
- Metal-backed, self-lubricating bearings/washers
- Nickel plating for trim parts
- Trunnion mounted ball

Options

B7.1

- PTFE various grades of reinforced gaskets, spring energized, for stem and seat sealing
- Metal-to-metal seats
- Double-barrier sealing in both directions (DPE)
- Body relief valve for overpressure
- Double block-and-bleed capabilities

Valve Construction

The B7 denomination identifies the side-entry ball valve ASME Class 2500.

Due to the high pressure and strong force involved, the materials selection is carried out by paying particular attention to the anti-extrusion features of the gaskets and to the resistance of the ball and stem materials.

GROVE B7.B

VALVE ASSEMBLY AND CROSS SECTION

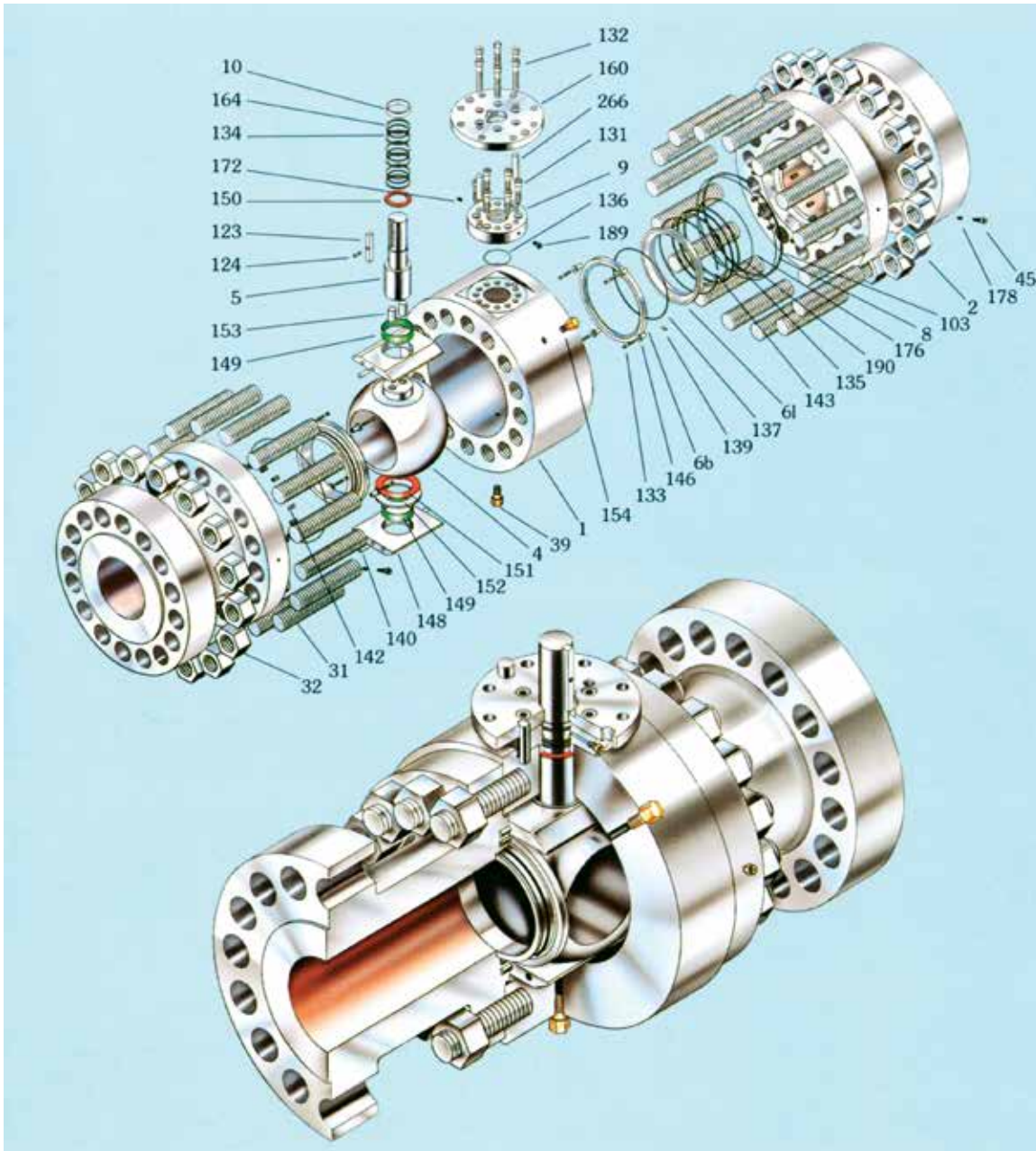

Item	Description	Item	Description	Item	Description
1	Body	123	Stem Key	149	Bearing
2	Closure	124	Stem Key Capscrew	150	Upper Thrust Washer
4	Ball	131	Gland Plate Capscrew	151	Lower Thrust Washer
5	Stem	132	Adapter Plate Capscrew	152	Spacer
6b	Outer Seat Ring	133	Puller Bushing Capscrew	153	Drive Pin
6l	Inner Seat Ring	134	Stem O-ring	154	Relief Valve
8	Body O-ring	135	Seat O-ring	160	Adapter Plate
9	Gland Plate	136	Gland Plate O-ring	164	Stem Backup Ring
10	Gland Bushing	137	Seal O-ring	172	Vent Plug
31	Body Stud	139	Seat Spring Pin	176	U-cup Packing
32	Body Stud Nut	140	Bearing Retainer Pin	178	Check Valve
39	Drain Valve	142	Spring	189	Gland Vent
45	Grease Fitting	143	Seat Lock Ring	190	Seat Backup Ring
103	Closure Backup Ring	146	Puller Bushing	299	Stop Spring Pin
		148	Bearing Retainer		

GROVE B7.1 and B7.B

DIMENSIONS AND WEIGHTS

ASME CLASS 2500

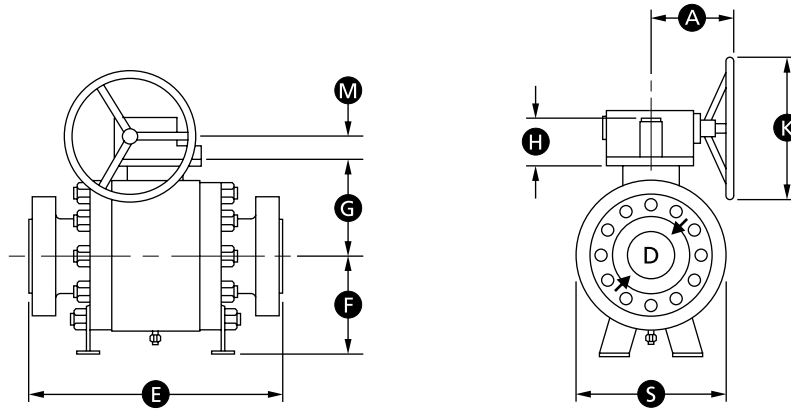

ASME CLASS 2500 – B7.1

SIZE	in. (mm)	D	E			F	G	S	H	L	A	K	M	WEIGHT	
			WE	RF	RTJ									WE	RF/RTJ
1-1/2	(40)	1-1/4 (32)	15-1/8 (384)	15-1/8 (384)	15-1/4 (387)	3-7/8 (98)	5-1/2 (140)	6-7/8 (175)	2-3/8 (60)	-	7-1/2 (191)	7-7/8 (200)	1-3/4 (44)	80 (36)	130 (59)
2 x 1-1/2 x 2	(50 x 40 x 50)	1-1/4 (32)	17-3/4 (451)	17-3/4 (451)	17-7/8 (454)	3-7/8 (98)	5-1/2 (140)	6-7/8 (175)	2-3/8 (60)	-	7-1/2 (191)	7-7/8 (200)	1-3/4 (44)	90 (41)	180 (82)
2	(50)	1-3/4 (44)	17-3/4 (451)	17-3/4 (451)	17-7/8 (454)	4-3/8 (111)	6-1/4 (159)	7-7/8 (200)	2-3/8 (60)	-	7-1/2 (191)	7-7/8 (200)	1-3/4 (44)	150 (68)	260 (118)
3 x 2 x 3	(80 x 50 x 80)	1-3/4 (44)	22-3/4 (578)	22-3/4 (578)	23 (584)	4-3/8 (111)	6-1/4 (159)	7-7/8 (200)	2-3/8 (60)	-	7-1/2 (191)	7-7/8 (200)	1-3/4 (44)	210 (95)	330 (150)
3	(80)	2-1/2 (64)	22-3/4 (578)	22-3/4 (578)	23 (584)	5-1/2 (140)	7-1/8 (181)	9-7/8 (251)	2-1/2 (64)	-	8-3/4 (222)	13-3/4 (349)	2-5/8 (67)	350 (159)	480 (218)
4 x 3 x 4	(100 x 80 x 100)	2-1/2 (64)	26-1/2 (673)	26-1/2 (673)	26-7/8 (683)	5-1/2 (140)	7-1/8 (181)	9-7/8 (251)	2-1/2 (64)	-	8-3/4 (222)	13-3/4 (349)	2-5/8 (67)	370 (168)	620 (281)
4	(100)	3-1/2 (89)	26-1/2 (673)	26-1/2 (673)	26-7/8 (683)	9-7/8 (251)	7-7/8 (200)	14-5/8 (372)	3 (76)	-	11-1/2 (292)	13-3/4 (349)	3 (76)	700 (318)	790 (358)
6 x 4 x 6	(150 x 100 x 150)	3-1/2 (89)	36 (914)	36 (914)	36-1/2 (927)	9-7/8 (251)	7-7/8 (200)	14-5/8 (372)	3 (76)	-	11-1/2 (292)	13-3/4 (349)	3 (76)	730 (331)	1250 (567)
6	(150)	5-1/4 (133)	36 (914)	36 (914)	36-1/2 (927)	11-3/8 (289)	9-1/4 (235)	16-7/8 (429)	4-5/8 (118)	-	11-1/2 (292)	13-3/4 (349)	3 (76)	1480 (671)	1650 (748)
8 x 6 x 8	(200 x 150 x 200)	5-1/4 (133)	40-1/4 (1022)	40-1/4 (1022)	40-7/8 (1038)	11-3/8 (289)	9-1/4 (235)	16-7/8 (429)	4-5/8 (118)	-	11-1/2 (292)	13-3/4 (349)	3 (76)	1890 (857)	2180 (989)

ASME CLASS 2500 – B7.B

SIZE	in. (mm)	D	E			F	G	S	H	L	A	K	M	WEIGHT	
			WE	RF	RTJ									WE	RF/RTJ
8	(200)	7-1/8 (181)	40-1/4 (1022)	40-1/4 (1022)	40-7/8 (1038)	15-1/8 (384)	15-1/2 (394)	26 (660)	4-5/8 (118)	-	15-3/4 (400)	23-5/8 (600)	4-3/8 (111)	3650 (1656)	4340 (1969)
10	(250)	8-7/8 (226)	50 (1270)	50 (1270)	50-7/8 (1292)	17-1/8 (435)	18-1/4 (464)	31-1/8 (790)	5-1/2 (140)	-	21-5/8 (549)	31-1/2 (800)	4-3/8 (111)	5480 (2486)	6590 (2989)
12	(300)	10-1/2 (267)	56 (1422)	56 (1422)	56-7/8 (1445)	19-5/8 (499)	20-1/2 (521)	34-1/4 (870)	5-1/2 (140)	-	21-5/8 (549)	31-1/2 (800)	4-3/8 (111)	7600 (3447)	9100 (4128)
14	(350)	12-1/4 (311)	(1)	(1)	(1)	22-7/8 (581)	24-3/4 (629)	39 (991)	8-1/8 (206)	-	21-3/4 (552)	23-5/8 (600)	5-3/8 (137)	9390 (4259)	11,220 (5089)
16	(400)	13-7/8 (353)	(1)	(1)	(1)	26-3/8 (670)	28-3/8 (721)	43-1/4 (1099)	8-1/8 (206)	-	21-3/4 (552)	23-5/8 (600)	5-3/8 (137)	11,330 (5139)	13,580 (6160)
18	(450)	15-5/8 (397)	(1)	(1)	(1)	29-1/8 (740)	31-7/8 (810)	47-7/8 (1216)	11 (279)	-	22-7/8 (581)	23-5/8 (600)	6-1/4 (159)	15,870 (7199)	19,020 (8627)
20	(500)	17-1/4 (438)	(1)	(1)	(1)	32-1/2 (826)	35-3/8 (899)	52-1/8 (1324)	11 (279)	-	22-7/8 (581)	23-5/8 (600)	6-1/4 (159)	21,420 (9716)	25,660 (11,639)

Flanges in accordance with ASME B16.5

Shaded bore sizes (D) according to API 6D

Shaded end-to-end dimensions (E) according to API 6D

Butt welding ends according to ASME B16.25

Outlined end-to-end dimensions (E) according to ASME B16.10

Quality System

Quality Assurance Program

ISO 9001:2000 and API Q1 Standards

All valves are designed in accordance with the most stringent industry procedures and standards and are built according to the European Directives PED and ATEX upon request.

Approvals

Cameron is an authorized licensee to use the American Petroleum Institute (API) monogram for specification API 6D and API 6A.

Certifications

- ISO 10423/API 6A
- ISO 14313/API 6D
- ISO 17423/API 6DSS

Inspection

Inspection is done per the Quality System requirements based on ISO 9001:2000 and API Q1. Cameron verifies all processes from material receipt to final customer inspection, including the liaison with third-party inspection and certifying authorities.

All products can be supplied with certified test reports, which include pressure testing, NDT, and chemical and



physical analysis, along with any other specified special test requirements.

The material certification of the valve parts can be furnished in accordance with DIN 50049-EN 10204 3.1 (at least) or 3.2.

Special Process

Cameron operates its own in-house electroless nickel plating (ENP) facility.

ASTM B656 and ASTM B733 are the reference standards for plating process and control. Strict quality control procedures for critical process conditions and for the plated components maintain plating consistency.

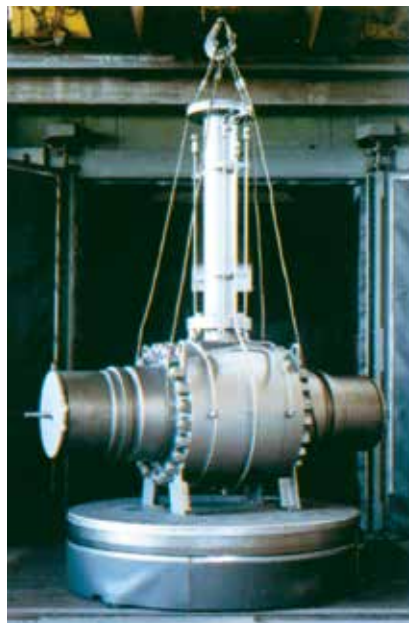

Qualification Testing

Research and Development Lab

Cameron's GROVE valves are designed in accordance with the applicable or requested codes and are subjected to full in-house qualification testing. Our in-house testing facilities, with the participation of the major oil and gas companies' R&D programs, allow Cameron to supply high-quality products.

Hydraulic and gas sealing tests, functional tests, and cycling and torque tests all are carried out on prototype valves. These test procedures ensure that the design safety factors, the maximum allowable leakage rates, and the expected valve service life are achieved.

Structural Verification

Cameron's engineering department operates an advanced 3D CAD system and conducts finite element analysis (FEA) to simulate various load conditions to determine a component's suitability for the intended service.

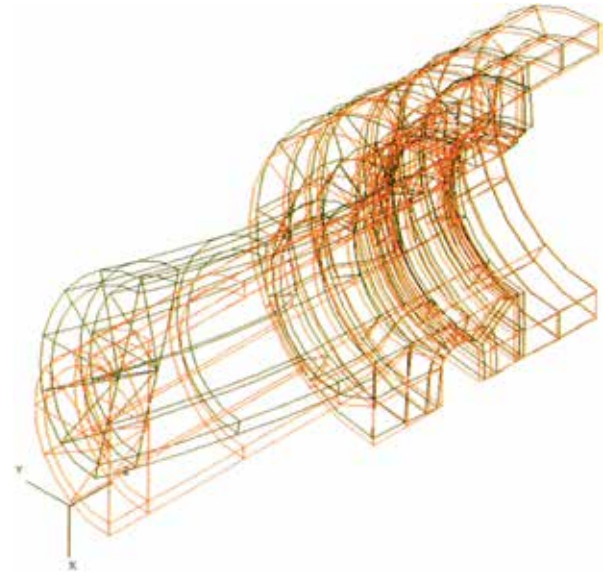

Fire-Safe Tests and Certifications

Cameron conducts in-house fire-safe testing, and its GROVE valves are certified in compliance with API 6FA and BS 6755 Part 2 fire-safe standards.

A complete reference list of qualified and certified valves can be made available upon customer's request.

Cycle Testing Under Flow Conditions

Through its in-house flow facility, Cameron verifies the behavior of valves subjected to cycle testing under dynamic flow conditions with the presence of abrasive particles. This test loop has the capacity to test valves up to 6" nominal bore with a maximum service pressure of 2900 psi (200 bar).

The main test parameters are PC entered and recorded for future design reference.

High-Pressure Gas Testing

Customers' specifications may dictate more severe testing in addition to conventional hydrostatic testing.

Cameron is fully equipped to carry out enhanced gas testing at ambient, low and high temperatures using specially equipped bunkers. External leakage rates (if any) are verified by means of a mass spectrometer. Leakage through the seats (if any) is verified by means of calibrated flow meters.

For low- and high-temperature service, gas testing can be performed to customer-specified critical dimensions. Cameron has test facilities for various valve dimensions. Testing can be performed at a range of temperatures from -184° F to 752° F (-120° C to 400° C).

Services for Valves and Actuation

WE BUILD IT. WE BACK IT.

Global Network and Local Support

Cameron is well-positioned to deliver total aftermarket support, quickly and efficiently, with unmatched OEM expertise. Our highly skilled engineers and technicians are available around the clock, seven days a week to respond to customer queries, troubleshoot problems and offer reliable solutions.

Easily Accessible Parts and Spare Valves

- OEM spare valves, actuators and parts (including non-Cameron brands)
- Handling, storage, packaging and delivery
- Dedicated stocking program

Comprehensive Services Portfolio

- Parts and spare valves
- Repair
- Field services
- Preventative maintenance
- Equipment testing and diagnostics
- Remanufacturing
- Asset preservation
- Customer property management
- Training and recertification services
- Warranty

Customized Total Valve CareSM (TVC) Programs

Customized asset management plans that optimize uptime, availability and dedicated services.

- Engineering consultancy
- Site management
- Flange management
- Startup and commissioning
- Spare parts and asset management
- Operational support



Trademark Information

GROVE is a registered trademark of Cameron.

This document contains references to registered trademarks or product designations, which are not owned by Cameron.



3250 Briarpark Drive, Suite 300

Houston, TX 77042

USA

Tel 1 281 499 8511

For more information on GROVE ball valves:

www.c-a-m.com/GROVE

GROVE@c-a-m.com



HSE Policy Statement

At Cameron, we are committed ethically, financially and personally to a working environment where no one gets hurt and nothing gets harmed.